



APPROVED MINUTES

November 18, 2022 Standards Committee Meeting

(3/10/23 - revised Actions for Item 11)

December 22, 2022

TO: Standards Committee

FROM: Scott Trammell, Secretary

RE: Minutes from the November 18, 2022 Standards Committee Meeting

The Standards Committee meeting was called to order by Mr. Pankow, Chair, at 09:00 a.m. on November 18, 2022, and was held virtually via *Teams* (Microsoft application). The meeting was adjourned at 11:10 a.m.

The following committee members were in attendance:

Gregory Pankow, Chairman, Director, Construction Management
Anne Rearick, Engineering and Asset Management
Dave Boruff, Traffic Engineering
Derrick Hauser*, Construction Management
Jim Reilman, Division of Materials and Tests
John Wooden, Division of Contract Administration
Kumar Dave, Pavement Engineering
Kurt Pelz, Construction Technical Support
Mark Orton, Highway Engineering
Mike Koch, District Construction, Fort Wayne District
Peter White, Bridge Engineering
*Proxy for Joseph Novak

Also, presence of the following throughout the meeting was captured by the *Microsoft Teams*:

Awwad, Nathan, INDOT
Barney, Bruce, INDOT
Bazlamit, Subhi M, INDOT
Blanchard, Jacob, INDOT
Corrice, Zachariah, INDOT
Duncan, Thomas, FHWA
Hailat, Mahmoud, INDOT
Harris, Tom, INDOT

Mueller, Bart, INDOT
Nelson, Mike, INDOT
Osborn, Dan, ICI
Podorvanova, Lana, INDOT
Ritter, John, INDOT
Russell, Melissa, INDOT
Siddiki, Nayyar Zia, INDOT
Thomas, Elizabeth, INDOT

Khan, Asfahan, INDOT

Thornton, Donald, INDOT
Trammell, Scott, INDOT

The following items were discussed:

A. GENERAL BUSINESS

OLD BUSINESS

(No items on this agenda)

NEW BUSINESS

1. *Approval of the **Minutes** from the [October 20, 2022](#) meeting*

Mr. Pankow requested a motion to approve the Minutes from the October 20, 2022 meeting.

Motion: Mr. Reilman

Second: Mr. Koch

Ayes: 9

Nays: 0

ACTION:

PASSED AS SUBMITTED

2. *Approval of the **Schedule of the Standards Committee meetings, proposals submittals, and distributions of the Agendas and the Minutes in 2023** (Mr. Trammell) [pg. 5](#)*

Please note that due to CEPDS (November) and APAI (December) conferences, the meeting dates may shift to Friday of those weeks. Please also be aware of the potential change to the January 2023 meeting due to the 2023 ITT Partnering Conference on January 18, 2023. Further updates on meetings effected by this conference will be addressed by Mr. Pankow.

B. CONCEPTUAL PROPOSAL

*2024 Standard Specifications (draft) (**Division 600**) editorial changes (K. Pelz) [pg. 6](#)*

C. STANDARD SPECIFICATIONS, SPECIAL PROVISIONS, AND STANDARD DRAWINGS PROPOSAL

OLD BUSINESS

(No items on this agenda)

NEW BUSINESS

<u>Item No. 1 (2022 SS)</u>	<u>Mr. Novak</u>	<u>pg 15</u>
Recurring Special Provision: 401-R-577	INERTIAL PROFILER WITH SMOOTHNESS PAY ADJUSTMENTS FOR HMA, FIXED INTERVAL	
ACTION:	PASSED AS SUBMITTED	
<u>Item No. 2 (2022 SS)</u>	<u>Mr. Novak</u>	<u>pg 25</u>
Recurring Special Provision: 501-R-752	INERTIAL PROFILER WITH SMOOTHNESS PAY ADJUSTMENTS FOR PCCP, FIXED INTERVAL	
ACTION:	PASSED AS SUBMITTED	
<u>Item No. 3 (2022 SS)</u>	<u>Mr. Reilman</u>	<u>pg 33</u>
2022 Standard Specifications: 507.10	Basis of Payment	
ACTION:	PASSED AS SUBMITTED	
<u>Item No. 4 (2022 SS)</u>	<u>Mr. Reilman</u>	<u>pg 37</u>
2022 Standard Specifications: DIVISION 700	STRUCTURES (<i>various sections</i>)	
ACTION:	PASSED AS SUBMITTED	
<u>Item No. 5 (2022 SS)</u>	<u>Mr. Reilman</u>	<u>pg 43</u>
2022 Standard Specifications: SECTION 707	PRECAST CONCRETE AND PRECAST, PRESTRESSED CONCRETE STRUCTURAL MEMBERS	
ACTION:	PASSED AS REVISED	
<u>Item No. 6 (2022 SS)</u>	<u>Mr. Reilman</u>	<u>pg 52</u>
Recurring Special Provision: 214-R-733	GEOSYNTHETICS	
ACTION:	PASSED AS SUBMITTED	
<u>Item No. 7 (2022 SS)</u>	<u>Mr. Reilman</u>	<u>pg 60</u>
Recurring Special Provision: 918-M-060	GEOSYNTHETIC MATERIALS	
ACTION:	PASSED AS SUBMITTED	
<u>Item No. 8 (2022 SS)</u>	<u>Mr. Reilman</u>	<u>pg 68</u>
Recurring Special Provision: 904-M-059	AGGREGATES	
ACTION:	PASSED AS SUBMITTED	

Item No. 9 (2022 SS) Mr. Reilman pg 75

2022 Standard Specifications:

602.06	Basis of Payment
702.03	Materials
702.22	Curing Concrete
709.08	Basis of Payment
912.02	Curing Sealing Materials Blank

ACTION: PASSED AS SUBMITTED

Item No. 10 (2022 SS) Mr. Reilman pg 81

2022 Standard Specifications:

503.02	Materials
503.03(e)	Terminal Joints
503.07	Method of Measurement
503.08	Basis of Payment
724.01	Description
724.02	Materials
724.03	General Requirements
906.07	Bridge Expansion Joints

Standard Drawings:

E 503-BATJ-02, -03	Terminal Joint
E 724-BSSJ series	EXPANSION JOINT

ACTION: PASSED AS SUBMITTED

Item No. 11 (2022 SS) Mr. White pg 102

2022 Standard Specifications:

714.03	General Requirements
714.04	Design Requirements
723.03	General Requirements
723.04	Design Requirements
723.10	Pedestals
723.14	<i>Precast Reinforced-Concrete Three-Sided Structure Section Joints</i>

ACTION: PASSED AS REVISED

Item No. 12 (2022 SS) Mr. Reilman pg 108

Recurring Special Provision:

106-C-XXX	<i>BUILD AMERICA, BUY AMERICA ACT REQUIREMENTS</i>
-----------	--

ACTION: PASSED AS REVISED

cc: Committee Members
FHWA
ICI

**Schedule of the Standards Committee meetings, proposals submittals,
and distributions of the Agendas and the Minutes in
2023**

Standards Committee Meeting Date	Agenda Items Due ⁽¹⁾	Agenda Distributed and Published	First Draft Minutes Distributed	Comments Due for Draft Minutes	Final Draft Minutes Distributed	Approved Minutes Published
on a 3rd Thursday of the month	(- 24 days)	(- 17 days)	(+ 6 days)	(+ 13 days)	(+ 21 days)	(+ 35 - 42 days)
Thursday, January 19, 2023	Monday, December 26, 2022	Tuesday, January 03, 2023	Wednesday, January 25, 2023	Wednesday, February 01, 2023	Thursday, February 09, 2023	Thursday, February 23, 2023
Thursday, February 16, 2023	Monday, January 23, 2023	Monday, January 30, 2023	Wednesday, February 22, 2023	Wednesday, March 01, 2023	Thursday, March 09, 2023	Thursday, March 23, 2023
Thursday, March 16, 2023	Monday, February 20, 2023	Monday, February 27, 2023	Wednesday, March 22, 2023	Wednesday, March 29, 2023	Thursday, April 06, 2023	Thursday, April 20, 2023
Thursday, April 20, 2023	Monday, March 27, 2023	Monday, April 03, 2023	Wednesday, April 26, 2023	Wednesday, May 03, 2023	Thursday, May 11, 2023	Thursday, June 01, 2023
Thursday, May 18, 2023	Monday, April 24, 2023	Monday, May 01, 2023	Wednesday, May 24, 2023	Wednesday, May 31, 2023	Thursday, June 08, 2023	Thursday, June 22, 2023
Thursday, June 15, 2023	Monday, May 22, 2023	Tuesday, May 30, 2023	Wednesday, June 21, 2023	Wednesday, June 28, 2023	Thursday, July 06, 2023	Thursday, July 20, 2023
Thursday, July 20, 2023	Monday, June 26, 2023	Monday, July 03, 2023	Wednesday, July 26, 2023	Wednesday, August 02, 2023	Thursday, August 10, 2023	Thursday, August 31, 2023
Thursday, August 17, 2023	Monday, July 24, 2023	Monday, July 31, 2023	Wednesday, August 23, 2023	Wednesday, August 30, 2023	Thursday, September 07, 2023	Thursday, September 21, 2023
Thursday, September 21, 2023	Monday, August 28, 2023	Tuesday, September 05, 2023	Wednesday, September 27, 2023	Wednesday, October 04, 2023	Thursday, October 12, 2023	Thursday, November 02, 2023
Thursday, October 19, 2023	Monday, September 25, 2023	Monday, October 02, 2023	Wednesday, October 25, 2023	Wednesday, November 01, 2023	Thursday, November 09, 2023	Thursday, November 30, 2023
Thursday, November 16, 2023	Monday, October 23, 2023	Monday, October 30, 2023	Wednesday, November 22, 2023	Wednesday, November 29, 2023	Thursday, December 07, 2023	Thursday, December 21, 2023
Thursday, December 21, 2023	Monday, November 27, 2023	Monday, December 04, 2023	Wednesday, December 27, 2023	Wednesday, January 03, 2024	Thursday, January 11, 2024	Thursday, February 01, 2024

Notes:

Agenda items must be submitted by the due date shown, and be accompanied by a Proposal sheet.

The ***February*** meeting is the last opportunity for the approval of the Standard Drawings effective on September 1, 2023.

Shaded dates are exceptions to the regular schedule.

CONCEPTUAL PROPOSAL ITEM

REVISION TO 2022 STANDARD SPECIFICATIONS: DIVISION 600 – INCIDENTAL CONSTRUCTION

CONCEPTUAL PROPOSAL TO STANDARDS COMMITTEE

PROBLEM(S) ENCOUNTERED: INDOT Standard Specifications have been in circulation since 1934 and have been regularly updated by adding new or revising existing statements, work procedures, materials, methods, etc.

Prior to publishing a 2024 Standard Specifications book (effective September 1, 2023), the review of the current edition is underway and a summary of proposed edits to the **DIVISION 600 – INCIDENTAL CONSTRUCTION** is shown.

PROPOSED SOLUTION (conceptual): Continue to review of all Divisions (100 thru 900) of the 2024 (draft) Standard Specifications and to make editorial (grammar) corrections as found necessary. Inform offices on questionable or outdated information and seek any necessary corrective action. Statements that are not clearly formulated or their written intentions are hard to follow have been rewritten, grammatical errors have been corrected and are proposed here for your review. Proposed revisions to Division 600 were made with this concept in mind and are shown here for your review.

APPLICABLE STANDARD SPECIFICATIONS: 2022 Standard Specifications and approved RSPs

APPLICABLE STANDARD DRAWINGS: n/a

APPLICABLE DESIGN MANUAL SECTION: n/a

APPLICABLE SECTION OF GIFE: n/a

APPLICABLE RECURRING SPECIAL PROVISIONS: various RSPs (if affected)

PAY ITEMS AFFECTED: n/a

APPLICABLE SUB-COMMITTEE ENDORSEMENT: ad-hoc Specification's review group: Kurt Pelz, Scott Trammell, Lana Podorvanova.

IMPACT ANALYSIS (attach report): n/a

Submitted By: Kurt Pelz

Title: Construction Management Technical Support

Organization: INDOT

Phone Number: 317-691-4800

Date: 10/31/2022

DIVISION 600 – INCIDENTAL CONSTRUCTION

SECTION 601 – GUARDRAIL

601.01 Description

This work shall consist of the fabrication, assembly, and installation of guardrail, guardrail transitions, and guardrail end treatments, in accordance with ~~these requirements, 105.03~~ and as shown on the plans. This work may also consist of the extension of existing guardrail with new guardrail, the removal of existing guardrail, or adjusting the height of existing guardrail.

[---]

601.02 Materials

Materials shall be in accordance with the following:

Alternate Material <i>Guardrail</i> Blockouts.....	926.03
Guardrail Posts.....	910.10
Guardrail Rail Accessories, Fittings, and Hardware	910.11
Steel Three-Beam Rail <i>Guardrail</i>	910.09
Steel W-Beam Rail	910.09
Timber Posts and Blockouts.....	911.02(f)

All guardrail, ~~post, accessories, fittings,~~ and *connection [previously approved by SC]* hardware shall be supplied from a manufacturer listed on the QPL of Guardrail Manufacturers in accordance with 910.09. Guardrail end treatments shall be selected from the QPL of Guardrail End Treatments in accordance with 601.07. ~~and~~ impact attenuators shall be selected from the QPL of Impact Attenuators in accordance with 601.08.

PCC in anchors, ~~and in~~ pads, or bases for impact attenuators shall be class A and in accordance with 702. Sheet signs and sign posts shall be in accordance with 802.

[601.02, line 42]

W-beam or Midwest Guardrail System, MGS, W-beam guardrail, components, assembly, post spacing, post lengths, and installation for each location shall be as shown on the plans. ~~Double facing of the Double faced~~ guardrail ~~will~~ shall be required at the locations shown on the plans. For W-beam guardrail, in locations where conditions will not allow the use of 7 ft posts, 6 ft posts may be substituted when approved. Timber posts may be used within a run of MGS W-beam guardrail as shown on the plans. Timber posts shall not be used within a run of W-beam guardrail.

[601.06, line 130]

An MGS guardrail transition, with or without curb, shall be required to connect guardrail to bridge rail, ~~and~~ guardrail to piers. An MGS height transition shall be required to connect MGS W-beam guardrail to existing W-beam or existing rub rail type guardrail. The required type of guardrail transition shall be as shown on the plans.

[---]

601.07 Guardrail End Treatments

Guardrail end treatments shall be required to terminate guardrail installations at the locations shown on the plans. ~~The~~ Type I guardrail end treatment shall be ~~either~~ as shown on the plans, or shall be selected from the QPL of Guardrail End Treatments. ~~The~~ Type II guardrail end treatment shall be as shown on the plans. ~~The~~ Type OS or MS guardrail end treatments shall be selected from the QPL of Guardrail End Treatments. The grading requirements shall be as shown on the plans.

[601.07, line 157]

Double facing of guardrail end treatment type I ~~will~~shall be required when it is used in conjunction with double faced guardrail.

When installing end treatments to existing rub rail type guardrail, the rub rail, if spliced at the last existing post, shall be cut and the end repositioned behind the flange of the post. If the rub rail is spliced at the last existing post, the existing splice material shall be removed; and the end of the rub rail repositioned behind the flange of the post. In both cases, the rub rail shall be connected to the post as shown on the plans.

Guardrail end treatments shall be installed within 24 h of the completion of the guardrail installation to which they are to be attached. Drums in accordance with 801.09 shall be placed for overnight marking of the bare end of the guardrail when the installation of the ~~guardrail~~ end treatment will not be completed until the day following the completion of the guardrail installation to which it is to be attached.

601.08 Impact Attenuators

Impact attenuators shall be placed or reset to obtain the proper height where shown on the plans. The unit for each new location shall be of the width recommended by the manufacturer and for the test level specified and shall be chosen from those shown on the QPL of Impact Attenuators. Each unit shall be placed in accordance with the manufacturer's recommendations; on a PCC pad.

Assembly, ~~and~~ installation, or resetting *of the guardrail end treatments* shall be supervised or performed ~~at all times~~ by an installer trained and certified by the unit's manufacturer; and shall be in accordance with the manufacturer's recommendations. The installer shall be included on the Department's list of Qualified Guardrail End Treatment and Impact Attenuator Installers prior to the start of work.

[601.08, line 189]

Transition panels and all other necessary hardware shown in the manufacturer's recommendations ~~to be required~~ for bi-directional traffic protection shall be included in the installation, or resetting, if the unit is installed at a location where traffic is passing the unit on both sides in opposite directions.

[---]

601.12 Resetting Guardrail

This work shall consist of the removal of existing guardrail ~~and~~; and if necessary, storing it; and then re-erecting ~~it~~ where shown on the plans or as directed.

[601.14, line 271]

Impact attenuators and resetting impact attenuators will be paid for at the contract unit price per each for the type, ~~and~~ width, and test level specified. The curved W-beam guardrail connector system and curved W-beam guardrail system will be paid for at the contract unit price per each for the type specified, complete in place.

[601.14, line 332]

The cost of resetting guardrail shall include the removal, necessary storage, resetting, and replacement of damaged or missing parts and new posts as required.

The cost of earthwork, grading, ~~and~~ transition panel, if required, and PCC pad shall be included in the cost of the impact attenuator. The cost of aggregate used to fill gravel barrel impact attenuators shall be included in the cost of the impact attenuator.

SECTION 602 – CONCRETE BARRIER

[602.03, line 28]

Concrete glare screen may only be precast when constructed in combination with new precast barrier. Concrete glare screen shall be cast-in-place when constructed in combination with cast-in-place barrier, and ~~also~~ when constructed on top of existing concrete barrier.

[602.03, line 66]

(c) Finishing

Concrete barrier and concrete glare screen shall be finished in accordance with 702.21. If slip-form construction is used, an approved brush finish will be allowed. Curing material in accordance with 912.01(e) shall be applied as a bond breaker to all areas which result in concrete-to-concrete contact. It shall be applied at a minimum rate of 1 gal./75 sq ft. If material is applied at a rate less than the minimum rate, a second application shall be applied.

SECTION 603 – FENCES

[603.03, line 28]

When the plans require that posts, braces, or anchors be imbedded in concrete, temporary guys or braces shall be installed, if required to hold the posts in proper position. Unless otherwise specified, no materials shall be installed on posts or strain placed on guys and bracing *shall be* set in concrete until 96 h have elapsed from the time of placing of the concrete.

At each location where an electric transmission, distribution, or secondary line crosses any of the types of fences covered by these specifications, a ground, conforming to applicable requirements of the National Electrical Safety Code, shall be furnished and installed.

Line posts for farm field type fence shall be set on 16 ft centers, and for chain link fence on 10 ft centers. In either case, a tolerance of ± 2 ft in spacing will be allowed at special locations as approved. Spacing of these posts shall be as uniform as practicable under the existing conditions. ~~However,~~ ~~a~~Additional posts shall be set to maintain the bottom clearance dimensions as required.

603.06 Resetting Fence

Resetting fence shall consist of the removal of existing fence within the specified limits and, if necessary, storing and ~~then~~ resetting it in accordance with the plans, or as directed. Resetting fence shall be in accordance with 603.03, 603.04, and 603.05. Damaged or missing parts, including posts shall be replaced.

[603.08, line 154]

The cost of adding grounding in accordance with the National Electrical Safety Code including all materials, and labor shall be included in the cost of the fence.

The cost of fence, and-corner, end, line, and pull posts shall be included in the cost of the fence.

The cost of fence *fabric for gates*, posts, and miscellaneous hardware shall be *included* in the cost of the gate.

The cost of all miscellaneous hardware related to the type of fence including brace connections, caps, clips, clamps, hinges, rivets, ties, truss rods, diagonal braces, and stretcher bars shall be included in the cost of the fence.

SECTION 604 – SIDEWALKS, CURB RAMPS, STEPS, AND HANDRAILS

[604.02, line 21]

Hand railing shall be aluminum pipe in accordance with ASTM B221, alloy 6063, temper T52, or galvanized steel pipe in accordance with ASTM A53, grade B, all as specified.

[604.03, line 87]

(e) Finishing

Immediately after striking off, the grade, running slopes and cross slopes shall be checked with a 2 ft level and a long handled straightedge of light construction that can completely span the surface. The level and straightedge shall be laid parallel and perpendicular to the grade or running slope at intervals of no more than 2 ft on curb ramps and 10 ft along sidewalks. All high spots shall be removed and depressions filled with fresh concrete and then leveled. Checking and leveling shall continue until the surface has the required grade, running slope and cross slope, and is free of voids.

[604.03, line 109]

Preformed 1/2 in. joint filler shall be placed around all appurtenances, such as manholes and utility poles which extend into and through the sidewalk, and between the sidewalk and any fixed structure, such as a building or bridge. The preformed joint filler shall extend for the full depth of the sidewalk or curb ramp, and shall be flush with the surface of the adjacent concrete.

[604.03, line 129]

Brick surfaces shall be installed in a running or stacked bond pattern with a 1/16 in average joint width. The joint width shall not exceed 1/8 in. Whole bricks should be laid first, followed by bricks cut to size, keeping the number of joints to a minimum. A masonry saw shall be used to produce a clean, accurate, and straight cut. The joint between bricks shall be completely filled with a dry fine aggregate. The fine aggregate may be obtained from a non-Certified Aggregate Producer, but it shall be natural sand having a gradation where at least 95% of the material passes the No. 4 sieve. Excess fine aggregate shall be removed from the surface of the bricks.

[604.05, line 168]

Such sidewalk shall be constructed to a minimum depth of 4 in. unless another depth is designated, and to the width of the adjoining walk, or to a width of no less than 48 in. from the back face of curb, or to such other width as directed.

The removal of concrete sidewalk shall be to uniform lines as directed. The sidewalk to be removed shall be cut in a straight line with an approved power driven concrete saw. The sawing shall be such that the portion of sidewalk to remain in place shall not be damaged. All portions which are damaged or removed beyond the established line shall be replaced.

[---]

604.09 Hand Rails Handrails

This railing Handrails shall be erected in a workmanlike manner, straight and true to grade. Posts shall be vertical and railings rails shall be parallel to the walk surface or the plane of the steps and spaced as shown on the plans. Fastenings shall be as indicated shown on the plans. Railing posts on masonry shall be held in place in a manner that develops the full strength of the railing post in bending.

Fabrication and placement of railings handrails shall be completed in accordance with the applicable requirements of 711. [---]

Steel pipe railing rails not designated to be painted shall be galvanized after fabrication and prior to installation. Railing Handrails designated to be painted shall receive one shop coat of paint after fabrication

and two field coats after installation. The type and color of paint shall be as specified on the plans. Cleaning and painting shall be in accordance with 619.

[604.10, line 275]

~~Hand rails~~ *Handrail* will be measured by the linear foot in accordance with the dimensions shown on the plans or as directed. Measurements will be made from end to end of the ~~railing~~ *handrail* along the centerline.

[604.11, line 293]

~~Hand rails~~ *Handrail* will be paid for at the contract unit price per linear foot.

SECTION 605 – CURBING

[605.03, line 28]

(b) Installation

The curb shall be set in accordance with the line and grade required. The face and top of the curb shall be checked with a 10 ft straightedge. Portions showing irregularities of 1/4 in. or more shall be removed and replaced with no additional payment. All spaces under the curbing shall be filled with *thoroughly tamped* bed course material. The bed course material shall be coarse aggregate No. 53 ~~and shall be thoroughly tamped.~~

(c) Joints

Curbing shall be ~~laid~~ *placed* with joints as ~~indicated~~ *shown* on the plans. These joints shall be filled with mortar as specified. Where a portland cement concrete pavement is to be constructed contiguous to a curbing, joints shall be constructed in the curbing directly in line with pavement expansion joints. The joint in the curbing shall be the same width as the pavement joint and shall be filled with an expansion joint filler of the nominal thickness as the pavement joint. Any voids between the joint filler and the curb shall be filled with mortar.

(d) Backfilling

After the curb has set, any remaining excavated areas shall be filled with approved material. This material shall be placed and thoroughly tamped in layers not ~~exceeding~~ *to exceed* 6 in. in depth.

[605.04, line 54]

(b) Forms

Forms shall be of wood or metal, straight, free from warp, and of such construction that there will be no interference to the inspection of grade or alignment. All forms shall extend for the entire depth of the curb and shall be braced and secured sufficiently so ~~that~~ no deflection from alignment or grade ~~shall~~ occurs during the placing of the concrete.

[605.04, line 70]

As an option, an integral curb and gutter may be placed at the same time as the PCCP pavement by the slip form method. The slip form machine shall have an attachment to place, consolidate, and shape the concrete to the required ~~shape~~ *profile* and dimensions. The reinforcing tie bars or stirrups between the pavement and the curb shall be omitted.

[605.04, line 109]

(f) Curing

Immediately upon completion of the rubbing, the curbing shall be moistened and kept moist for three days, or cured by ~~the use of~~ *using* membrane forming material. The method and details of curing shall

CONCEPTUAL PROPOSAL ITEM

REVISION TO 2022 STANDARD SPECIFICATIONS: DIVISION 600 – INCIDENTAL CONSTRUCTION

be subject to approval.

[605.05, line 132]

Washed mortar sand shall meet all the requirements for mortar sand and shall be of a ~~light~~ satisfactory *light* color. The reflecting surface mortar shall be placed immediately after the placing of the base concrete. No more than 20 minutes shall elapse between the placing of the base concrete and the placing of the reflecting surface.

[605.08, line 229]

(d) Resetting

The curb shall be set on a firm bed in accordance with the required line and grade. All sections of curbing shall be set so that the maximum opening between adjacent sections is 3/4 in. wide for the entire exposed top and face. Any dressing of the ends of the curbing necessary to meet this requirement shall be ~~done~~ performed as needed. Cutting or fitting may be necessary in order to install the curbing at the locations as directed.

[---]

(e) Backfilling

The spaces in front and back of the curb shall be refilled to the required elevation with suitable material. This material shall be tamped thoroughly in layers of ~~not over~~ *not to exceed* 6 in. in depth.

SECTION 608 – SHOULDER DRAINS

[608.03, line 25]

After the trench has been prepared, it shall be backfilled to the required elevation with aggregate, and then be well compacted. ~~After this, a~~ Any remaining unfilled trench area shall be filled with material approved for shoulders and compacted by rolling or tamping or both. The finished shoulder elevation shall conform with that required at that point *be as shown on the plans.*

SECTION 609 – REINFORCED CONCRETE BRIDGE APPROACHES

609.11 Smoothness

The smoothness of the surface of the RCBA will be measured by means of a 10 ft ~~long~~ straightedge as soon as practical following curing or completion of adjoining roadway or structure sections. All surface variations shall be corrected to 1/8 in. or less.

SECTION 611 – MAILBOX INSTALLATION

Mailbox assemblies shall be furnished and installed as shown on the plans. Alternate mailbox assemblies which have been crash tested and approved in accordance with ~~NCHRP 350~~ *AASHTO MASH(????)* requirements may be considered upon receipt of a written request. Alternate mailbox assemblies approved for use shall be furnished and installed in conformance with the manufacturer's recommendations.

SECTION 612 – UNDERSEALING

[612.06, line 93]

The hardwood plugs shall be inspected after any milling operation ~~in the case where~~ *when a*

resurface exists on the concrete. Damaged or missing plugs shall be replaced prior to overlaying with a new surface.

SECTION 616 – RIPRAP AND SLOPEWALL

616.03 Placing Dumped Riprap

Dumped riprap shall be placed to produce a surface of approximate regularity ~~but~~ *and may not need not necessarily* to be hand placed. The finished surface shall vary no more than 9 in. from a true plane. The thickness perpendicular to its surface shall be no more than 2 ft nor less than 1 ft unless otherwise directed.

[---]

616.05 Placing Revetment, Class 1, and Class 2 Riprap

Revetment, class 1, and class 2 riprap may be placed by dumping and shall be placed to the required thickness. The finished surface shall be free from clusters of small *or large* stones ~~or of large ones~~. The finished surface shall vary from a true plane no more than 9 in. for revetment riprap or 18 in. for class 1 or class 2 riprap. *The placed riprap* ~~but~~ shall not be less than the minimum depth specified.

[---]

616.08 Placing Precast Cement Concrete Riprap

The slope on which the riprap is to be placed shall be in accordance with that shown on the plans unless otherwise designated. ~~Laying~~ *Placement* shall begin in a trench below the toe of the slope and progress upward. Each piece shall be ~~laid~~ *placed* by hand perpendicular to the slope. It shall be firmly embedded against the slope in such a manner that the vertical joint space between individual units does not exceed 3/8 in., unless otherwise specified. Half blocks, odd shaped blocks, or class A concrete shall be used to fill the voids at the ends of sections to be placed or on curved shaped sections. The top course shall conform, as nearly as practicable, with the prescribed berm or shoulder elevation. Any adjustment necessary to achieve this shall be obtained by constructing a wedge course near the top of the slope as directed. This wedge course, when required, shall consist of class A concrete. If the thickness of the course does not allow class A concrete, it shall be constructed of a 1:2 mortar proportioned by volume. Toewalls, when required, shall consist of class A concrete.

616.09 Slopewall

The slope on which *the* slopewall is to be placed shall be in accordance with that shown on the plans unless ~~a different slope is~~ *otherwise* designated.

[---]

616.11 Installation of Geotextile Under Riprap

Storage and handling of geotextiles shall be in accordance with the manufacturer's recommendations, ~~except that the~~ *Geotextile shall not be stored in such a manner as to prevent exposed* ~~exposure~~ to direct sunlight, ultraviolet rays, water, temperature greater than 140°F, mud, dirt, dust, and debris, ~~to the extent that its strength, toughness, or permeability requirements are diminished~~. Each geotextile roll shall be labeled or tagged to provide product identification sufficient for inventory and quality control purposes. Exposure of geotextiles to the elements between lay down and cover shall be a maximum of 14 *calendar* days. ~~At the time of installation, the geotextile shall be rejected and replaced with no additional payment if defects, rips, flaws, deterioration or damage incurred during manufacture, transportation, storage, or construction is evident~~ *at the time of installation, the geotextile will be rejected and shall be replaced with no additional payment.*

[616.11, line 119]

Geotextiles used for 2:1 slopes ~~or greater~~ *steeper slopes* shall be placed with the machine direction

of the geotextile sheets perpendicular to the toe of slope. The geotextile sheets shall be overlapped in the direction of the anticipated movement of water.

616.12 Method of Measurement

Dumped, revetment, class 1, and class 2 riprap obtained from outside the right-of-way will be measured by the ton. If obtained from inside the right-of-way, no measurement will be made if placed as shown on the plans unless direct payment is specified. If placed at locations not shown on the plans, measurement will be made by the square yard.

[---]

616.13 Basis of Payment

The accepted quantities of dumped, revetment, class 1, and class 2 riprap obtained from outside the right-of-way will be paid for at the contract unit price per ton. Dumped, revetment, class 1, and class 2 riprap obtained from within the project limits will be paid for at the contract unit price per square yard. Uniform riprap will be paid for at the contract unit price per ton. Grouted riprap will be paid for at the contract unit price per square yard of the specified depth. Precast concrete riprap, and concrete sloped wall will be paid for at the contract unit price per square yard, all complete in place. If slag is used as dumped riprap and payment will be made per ton, the pay quantity will be adjusted in accordance with 904.01.

SECTION 622 – PLANTING TREES, SHRUBS, AND VINES

[622.03, line 58]

(b) Balled and Burlapped Plants and Container Grown Plants

Plants shall be planted or placed in storage before being exposed for 10 consecutive hours at temperatures less than 35°F. Storage of plants shall be in a moist storage building or they shall be placed outside in a compact group with balls or containers completely covered with corncobs and kept moist. Plants shall not remain in storage for more than 10 days, unless otherwise specified ~~because of due to~~ unfavorable planting conditions.

Plants may be rejected ~~en~~ upon failure to comply with these specifications.

622.04 Collected Plants

At least 24 h before starting to dig collected plants, notification shall be given of the time and place of digging so inspection of the work and of the plants can be made, ~~if so~~ desired.

[---]

622.11 Guying and Staking

Guying and staking shall be in accordance with the details shown on the plans. Guy wire shall be placed through rubber hose material around each tree then twisted to secure the tree in a relatively stable position. Three wood stakes shall be spaced equally about each tree. The guy wire shall be secured to each stake at an approximately right angle. Support of multi-stem trees of 4 to 6 ft in height shall consist of inner limb guying and bracing stakes. The securement point and placement of guy wire shall ~~be so as to~~ avoid abrasion of tree limbs. The guys and stakes shall be maintained for the duration of the contract. Prior to final inspection, all materials used to support trees shall be removed and disposed of, except as otherwise directed for trees requiring additional bracing time. However, supports for fall replacement shall remain in place. If approved, stakes may be left flush with the ground.

[END OF PROPOSED EDITS]

PROPOSAL TO STANDARDS COMMITTEE

PROBLEM(S) ENCOUNTERED: In preparation for the conversion from profilograph to high-speed inertial profilers in 2023, INDOT has been working with FHWA to establish QA program requirements. This QA is required because Contractor's data is used as the basis for acceptance and payment. The current specification does not include program level QA requirements.

PROPOSED SOLUTION: Add program level QA requirements to the spec. Also, some editorial changes are proposed.

APPLICABLE STANDARD SPECIFICATIONS: 401.20

APPLICABLE STANDARD DRAWINGS: N/A

APPLICABLE DESIGN MANUAL SECTION: N/A

APPLICABLE SECTION OF GIFE: 5.16, 8.13, 13.4, 13.17

APPLICABLE RECURRING SPECIAL PROVISIONS: 401-R-577

PAY ITEMS AFFECTED: None

APPLICABLE SUB-COMMITTEE ENDORSEMENT: n/a

IF APPROVED AS RECURRING SPECIAL PROVISION OR PLAN DETAILS, PROPOSED BASIS FOR USE:
Unchanged from current.

IMPACT ANALYSIS (attach report): Attached

Submitted By: Joe Novak

Title: State Construction Engineer

Organization: INDOT Construction Management

Phone Number: 317-501-7805

Date:

IMPACT ANALYSIS REPORT CHECKLIST

Explain the business case as to why this item should be presented to the Standards Committee for approval. Answer the following questions with Yes, No or N/A.

Does this item appear in any other specification sections? N

Will approval of this item affect the Approved Materials List? N

Will this proposal improve:

Construction costs? N/A

Construction time? N/A

Customer satisfaction? N/A

Congestion/travel time? N/A

Ride quality? N/A

Will this proposal reduce operational costs or maintenance effort? N/A

Will this item improve safety:

For motorists? N/A

For construction workers? N/A

Will this proposal improve quality for:

Construction procedures/processes? N/A

Asset preservation? N/A

Design process? N/A

Will this change provide the contractor more flexibility? N/A

Will this proposal provide clarification for the Contractor and field personnel? Yes

Can this item improve/reduce the number of potential change orders? N/A

Is this proposal needed for compliance with:

Federal or State regulations? N

AASHTO or other design code? N

Is this item editorial? N

Provide any further information as to why this proposal should be placed on the Standards Committee meeting Agenda: N/A

REVISION TO RECURRING SPECIAL PROVISION

401-R-577 INERTIAL PROFILER WITH SMOOTHNESS PAY ADJUSTMENTS FOR HMA, FIXED INTERVAL

401-R-577 INERTIAL PROFILER WITH SMOOTHNESS PAY ADJUSTMENTS FOR HMA,
FIXED INTERVAL

(Revised 08-18-22)

The Standard Specifications are revised as follows:

SECTION 401, DELETE LINES 593 THROUGH 705.

SECTION 401, AFTER LINE 705, INSERT AS FOLLOWS:

401.18 Pavement Smoothness

Pavement smoothness will be accepted by means of an inertial profiler, a 16 ft long straightedge, or a 10 ft long straightedge as described below.

(a) Inertial Profiler with Smoothness Pay Adjustments

When a pay item for Inertial Profiler, HMA is included in the contract, the Contractor shall furnish, calibrate, and operate an approved inertial profiler in accordance with ITM 917 for the acceptance of longitudinal smoothness on the mainline traveled way, including adjacent acceleration or deceleration lanes, where all of the following conditions are met:

- 1. The posted speed is greater than 45 mph.*
- 2. The traveled way width and slope are constant and is at least 0.5 mi in length.*
- 3. The HMA is placed on a milled surface and the planned lay rate for a single lift is 165 lb/sq yd or greater, or the total combined planned lay rate of surface, intermediate, and base courses is 385 lb/sq yd or greater.*

The profiles, and International Roughness Index, IRI, results including areas of localized roughness, and fixed interval IRI results produced shall become the property of the Department. The inertial profiler shall remain the property of the Contractor.

The project area will be divided into individual smoothness sections measuring 0.1 mi in length for each lane. The paving exceptions and areas exempt from inertial profiler operation will be in accordance with ITM 917.

If the posted speed limit for an entire smoothness section is less than or equal to 45 mph, the section will be exempt from Inertial Profiler operation and the smoothness within the section will be accepted in accordance with 401.18(b).

If the posted speed limit is greater than 45 mph for a portion of a smoothness section and is less than or equal to 45 mph for the remainder, the section smoothness acceptance will be as follows:

- 1. By inertial profiler for the portion of the section with a posted speed limit greater than 45 mph.*

REVISION TO RECURRING SPECIAL PROVISION

401-R-577 INERTIAL PROFILER WITH SMOOTHNESS PAY ADJUSTMENTS FOR HMA, FIXED INTERVAL

2. *In accordance with 401.18(b) for the portion of the section with a posted speed limit less than or equal to 45 mph.*

At locations where the inertial profiler is required, it shall be used on the surface course and on any dense graded intermediate course immediately below the surface course.

(b) 16 ft Straightedge

The Contractor shall furnish and operate a 16 ft straightedge in accordance with 306.03(d) and as described below. The 16 ft straightedge shall be used to measure smoothness along the direction of mainline traffic.

Locations on the pavement surface scraped by the straightedge shall be marked. The pavement shall be corrected in accordance with 401.18(e) to meet the required tolerance. For existing utility and manhole castings that required no grade adjustment, the tolerance may be adjusted after being reviewed and approved by the Engineer.

For contracts which include the Inertial Profiler, HMA pay item, the 16 ft ~~long~~-straightedge or the Inertial Profiler simulating the 16 ft ~~long~~-straightedge shall be used to measure longitudinal smoothness on surface courses at the following locations:

1. *All mainline traveled way lanes shorter than 0.5 mi.*
2. *All mainline traveled way lanes at locations exempted from inertial profiler operation in accordance with ITM 917.*
3. *All mainline traveled way lanes within smoothness sections with posted speed limits less than or equal to 45 mph throughout the entire section length.*
4. *All tapers.*
5. *All ramps.*
6. *All turn lanes, including bi-directional left turn lanes shorter than 0.5 mi.*
7. *All acceleration and deceleration lanes associated with ramps with posted speeds of 45 mph or less.*
8. *All shoulders.*
9. *All intersections with significant change in cross slope.*

For contracts where the inertial profiler is not used for smoothness acceptance, the 16 ft straightedge shall be used to measure longitudinal smoothness on all surface courses, and on any dense graded intermediate course immediately below the surface course. Measurement with the 16 ft straightedge shall include the above locations, all mainline traveled way lanes and ramps with posted speeds greater than 45 mph, and on ramp acceleration or deceleration lanes.

REVISION TO RECURRING SPECIAL PROVISION

401-R-577 INERTIAL PROFILER WITH SMOOTHNESS PAY ADJUSTMENTS FOR HMA, FIXED INTERVAL

(c) 10 ft Straightedge

The 10 ft straightedge will be in accordance with 306.03(d). The 10 ft straightedge will be used to check transverse slopes, across travel lanes and shoulders, approaches, and crossovers. When the 10 ft straightedge is used, the pavement variations shall be corrected to 1/8 in. or less.

(d) Areas of Localized Roughness, ALR

At locations where the inertial profiler is being used on an intermediate course, all areas having a localized roughness in excess of 160 in./mi utilizing continuous IRI with a 25 ft window shall be corrected subject to approval by the Engineer.

At locations where the inertial profiler is being used on a surface course, all areas under category Type A, as defined in 401.19(c), having a localized roughness in excess of 160 in./mile or category Type B in excess of 170 in./mile utilizing continuous IRI with a 25 ft window shall be corrected subject to approval by the Engineer. After ALR's have been identified, a grinding simulation shall be performed to estimate whether the ALR can be corrected to an IRI value of less than 160 in./mi with no more than a 1/4 in. max grind depth at any spot. If such correction is not possible, then an ALR with an IRI value of less than 190 in./mi can remain uncorrected if approved by the Engineer, and an ALR with an IRI value greater than 190 in./mi shall require full depth removal and replacement of the surface course of sufficient area to meet specifications.

In addition, if there is only one ALR in any two-lane mile section, then no smoothness correction will be required if the ALR does not exceed 190 in./mi and the overall smoothness in accordance with 401.18(d) of the two-lane mile section does not require any corrective action. A two-lane mile section will start one mile before the ALR and end one mile after the ALR in order that all two-lane mile sections will have, at most, one ALR each.

(e) Smoothness Section Correction

The width of the corrected area may be partial or full lane width, depending on the respective wheel path profiles. Underlying courses that are exposed by corrective action shall be milled to a depth of 1 1/2 in. and replaced with surface course. After the corrective action is taken on a surface course, the inertial profiler shall be operated throughout the entire affected smoothness section to verify the adequacy of the corrective action.

At locations where the 16 ft straightedge is used, the pavement variations shall be corrected to 1/4 in. or less.

If grinding of an intermediate course is used for pavement smoothness corrections, the grinding shall not precede the surface placement by more than 30 calendar days if open to traffic.

SECTION 401, DELETE LINES 805 THROUGH 843.

SECTION 401, AFTER LINE 843, INSERT AS FOLLOWS:

(c) Smoothness

Smoothness pay adjustments will only be applied when the smoothness is measured by an inertial profiler in accordance with 401.18(a).

The Mean Roughness Index, MRI, will be determined utilizing a fixed interval for each lane for each 0.1 mile section of paving. The MRI for a 0.1 mile section will be the average of the IRI of the two wheel paths. Categorized segments shall be as follows:

REVISION TO RECURRING SPECIAL PROVISION

401-R-577 INERTIAL PROFILER WITH SMOOTHNESS PAY ADJUSTMENTS FOR HMA, FIXED INTERVAL

1. *Type A. Pavement on a non-interstate with more than a single opportunity to achieve a smooth ride or asphalt pavement on an interstate with a single opportunity or more. The following operations, if performed on the contract, will be considered opportunities.*
 - a. *A layer of HMA base, intermediate, and surface; each layer is an opportunity. Wedge and level will not be considered an opportunity.*
 - b. *Profile milling to correct cross slope is considered an opportunity prior to placing base, intermediate, or surface HMA.*
2. *Type B. Pavement that is not included in the description above under Type A.*

At locations where an inertial profiler is used to accept smoothness, a quality assurance adjustment will be determined for each lane. This adjustment will be applied to all QC/QA HMA pay items within the pavement section. The adjustment will be calculated using the following formula:

$$q_s = (PF_s - 1.00) \sum_{i=1}^n \left(A \times \frac{S}{T} \times U \right)$$

where:

- q_s = quality assurance adjustment for smoothness for one section*
PF_s = pay factor for smoothness
n = number of layers
A = area of the section, sq yd
S = planned spread rate for material, lb/sq yd
T = conversion factor: 2,000 lb/ton
U = unit price for the material, \$/ton.

The quality assurance adjustment for smoothness, Q_s, for the contract will be the total of the quality assurance adjustments for smoothness, q_s, on each section by the following formula:

$$Q_s = \sum q_s$$

When smoothness is measured by an inertial profiler, payment adjustments will be made for any 0.1 mile section based on initial MRI generated on the surface course only and in accordance with the following table. Smoothness correction, if required, shall be in accordance with 401.18(e). The MRI pay factors for smoothness will be determined prior to any required smoothness correction.

<i>PAY FACTORS FOR SMOOTHNESS</i>	
<i>Posted Speed greater than 45 mph</i>	
<i>MRI, in./mi.</i>	<i>Pay Factor, PFs</i>
<i>over 0 to 35</i>	<i>1.06</i>
<i>over 35 to 40</i>	<i>1.05</i>

REVISION TO RECURRING SPECIAL PROVISION

401-R-577 INERTIAL PROFILER WITH SMOOTHNESS PAY ADJUSTMENTS FOR HMA, FIXED INTERVAL

<i>over 40 to 45</i>	<i>1.04</i>
<i>over 45 to 50</i>	<i>1.03</i>
<i>over 50 to 55</i>	<i>1.02</i>
<i>over 55 to 60</i>	<i>1.01</i>
<i>over 60 to 70</i>	<i>1.00</i>
<i>over 70 to 75</i>	<i>0.99</i>
<i>over 75 to 80</i>	<i>0.98</i>
<i>over 80 to 85</i>	<i>0.96</i>
<i>over 85 to 90</i>	<i>0.95</i>
<i>over 90</i>	<i>For Type A, PFs will be 0.95 and the section shall be corrected to 70 or less.</i>
<i>over 90 to 110</i>	<i>For Type B, PFs will be 0.95 and the section does not require correction.</i>
<i>over 110</i>	<i>For Type B, PFs will be 0.95 and the section shall be corrected to 90 or less.</i>

SECTION 401, BEGIN LINE 844, INSERT AS FOLLOWS:

401.20 Appeals

(a) Dense Graded Mixtures and Open Graded Mixtures

SECTION 401, BEGIN LINE 883, DELETE AND INSERT AS FOLLOWS:

~~(a)~~1. MSG

The backup MSG will be dried in accordance with ITM 572 and mass determined in water in accordance with AASHTO T 209.

~~(b)~~2. BSG of the Gyrotory Specimen

New gyrotory specimens will be prepared and tested in accordance with AASHTO T 312 from the backup sample.

~~(c)~~3. Binder Content

The backup binder content sample will be prepared and tested in accordance with ITM 571.

~~(d)~~4. BSG of the Density Core

Additional cores shall be taken within seven calendar days unless otherwise directed. Additional core locations will be determined by adding 1 ft longitudinally of the cores tested using the same transverse offset. The appeal density cores will be dried in accordance with ITM 572 and tested in accordance with AASHTO T 166, Method A or AASHTO T 331, if required.

The appeal results will replace all previous test result for acceptance of mixture in accordance with 401.09 and density in accordance with 401.16. The results will be furnished to the Contractor.

(b) Smoothness

The Department will perform annual Quality Assurance reviews of a portion of each

REVISION TO RECURRING SPECIAL PROVISION

401-R-577 INERTIAL PROFILER WITH SMOOTHNESS PAY ADJUSTMENTS FOR HMA, FIXED INTERVAL

Contractor's MRI results in accordance with ITM 917. The Contractor's results will be compared to the Department's. The Department will notify the Contractor of unacceptable results in a timely manner. The Department will allow an appeal period of 14 days during which time the Contractor must submit a written request and appeal results for Department review. If the Contractor's appeal results do not agree with the Department's results, the Contractor shall be required to perform a side-by-side evaluation. The Department's results will be utilized for smoothness payment in place of the Contractor's results unless the Contractor's appeal results are determined to be acceptable for payment. Sections where corrective action has taken place prior to the Department's data collection will utilize the Contractor's initial results prior to corrective action for payment.

SECTION 401, BEGIN LINE 916, DELETE AND INSERT AS FOLLOWS:

401.22 Basis of Payment

The accepted quantities for this work will be paid for at the contract unit price per ton for QC/QA-HMA, of the type specified, complete in place.

Payment for furnishing, calibrating, and operating the ~~profilograph~~ *inertial profiler*, and furnishing IRI profile information will be made at the contract lump sum price for ~~profilograph~~ *Inertial Profiler, HMA*.

Furnishing and operating the 16 ft straightedge shall be included in the cost of other pay items within this section.

Adjustments to the contract payment with respect to mixture, density, and smoothness for the mixture produced will be included in a quality adjustment pay item in accordance with 109.05.1.

SECTION 401, BEGIN LINE 940, DELETE AND INSERT AS FOLLOWS:

~~Profilograph~~ *Inertial Profiler, HMA*.....LS

SECTION 401, BEGIN LINE 964, DELETE AND INSERT AS FOLLOWS:

The price for ~~Profilograph~~ *Inertial Profiler, HMA* will be full compensation regardless of how often the ~~profilograph~~ *inertial profiler* is used or how ~~many profilograms are produced~~ *often the IRI is determined*.

SECTION 402, BEGIN LINE 344, DELETE AND INSERT AS FOLLOWS:

402.18 Pavement Smoothness

Pavement smoothness will be in accordance with 401.18 except ~~profilograph~~ *inertial profiler* requirements will not apply.

COMMENTS AND ACTION

401-R-577 INERTIAL PROFILER WITH SMOOTHNESS PAY ADJUSTMENTS FOR HMA, FIXED INTERVAL

DISCUSSION:

This item was introduced and presented by Mr. Hauser, sitting in as proxy for Mr. Novak, and assisted by Mr. Blanchard who explained that in preparation for the conversion from profilograph to high-speed inertial profilers in 2023, INDOT has been working with FHWA to establish QA program requirements. This QA is required because the Contractor's data is used as the basis for acceptance and payment. The current specification does not include program level QA requirements.

Mr. Hauser proposed to add program level QA requirements to the spec. Also, some editorial changes are proposed, as shown.

Mr. Koch stated that the Profilograph was an involved process that took considerable time, effort, and MOT exposure to run; as such it was generally run once. IRI improves these shortcomings yet has the potential for multiple runs to see if the numbers improve. Do we care if a Contractor does not provide a portion of the IRI until a later date within the duration of the contract time?

Mr. Blanchard responded that we do not discuss phasing with respect to collecting and submitting data in the spec or ITM, we do ask about this on our IRI Data Submission form, so we are expecting this to happen. Our view is that it's to the Contractors advantage to collect smoothness data sooner rather than later, as the roughness will only increase with time. The current 401 profilograph spec does not have a requirement for timing on checking smoothness, although the 501 discusses checking smoothness if requested within 24 hours.

Mr. Koch said that the language would require a review of each of our 9 Contractors currently certified to operate the 13 certified devices. Some larger Contractors with multiple devices likely have the Profiler stationed within different regions. Should the QA focus on the Contractor or Profiler? Mr. Blanchard replied that it's a good question which will be addressed in the details of our QA program and JTRP's management of QA department testing. The spec language we've used is attempting to mirror the 401 HMA testing involving plates/core, so we use terms like "Contractor" and "Department" and "results" and "appeal period". Also keep in mind that we are certifying Contractor's equipment annually and operator's Triennially, but also require PEMS to check the equipment when it arrives on site with bounce, block, and DMI checks per ITM 917.

Mr. Koch asked if the required information will be included in the specifications so the Contractor doesn't have to look in numerous places for information. Mr. Blanchard responded that yes, the information will be in the specifications and the GIFE.

There was no further discussion and this item passed as submitted.

COMMENTS AND ACTION

401-R-577 INERTIAL PROFILER WITH SMOOTHNESS PAY ADJUSTMENTS FOR HMA, FIXED INTERVAL

[continued]

	<u>Action:</u>	
Motion: Mr. Hauser Second: Mr. Koch Ayes: 9 Nays: 0 FHWA Approval: Yes	<u>X</u> — —	Passed as Submitted Passed as Revised Withdrawn
2022 Standard Specifications Sections referenced and/or affected: 401.18 begin pg 315.	<u>X</u> — —	2024 Standard Specifications Revise Pay Items List Create RSP (No. ___) Effective:
Recurring Special Provisions or Plan Details: 401-R-577 INERTIAL PROFILER WITH SMOOTHNESS PAY ADJUSTMENTS FOR HMA, FIXED INTERVAL	<u>X</u>	Revise RSP (No. <u>401-R-577</u>) Effective: <u>June 1, 2023</u>
Standard Drawing affected: NONE	—	Standard Drawing Effective:
Design Manual Sections affected: NONE	—	Create RPD (No. ___) Effective:
GIFE Sections cross-references: 5.16, 8.13, 13.4, 13.17	<u>X</u> — —	GIFE Update Frequency Manual Update SiteManager Update

PROPOSAL TO STANDARDS COMMITTEE

PROBLEM(S) ENCOUNTERED: In preparation for the conversion from profilograph to high-speed inertial profilers in 2023, INDOT has been working with FHWA to establish QA program requirements. This QA is required because Contractor's data is used as the basis for acceptance and payment. The current specification does not include program level QA requirements.

PROPOSED SOLUTION: Add program level QA requirements to the spec. Also, some editorial changes are proposed.

APPLICABLE STANDARD SPECIFICATIONS: 501.29

APPLICABLE STANDARD DRAWINGS: N/A

APPLICABLE DESIGN MANUAL SECTION: N/A

APPLICABLE SECTION OF GIFE: 5.16, 8.13, 13.4, 13.17

APPLICABLE RECURRING SPECIAL PROVISIONS: 501-R-752

PAY ITEMS AFFECTED: None

APPLICABLE SUB-COMMITTEE ENDORSEMENT: n/a

IF APPROVED AS RECURRING SPECIAL PROVISION OR PLAN DETAILS, PROPOSED BASIS FOR USE:
Unchanged from current.

IMPACT ANALYSIS (attach report): Attached

Submitted By: Joe Novak

Title: State Construction Engineer

Organization: INDOT Construction Management

Phone Number: 317-501-7805

Date:

IMPACT ANALYSIS REPORT CHECKLIST

Explain the business case as to why this item should be presented to the Standards Committee for approval. Answer the following questions with Yes, No or N/A.

Does this item appear in any other specification sections? N

Will approval of this item affect the Approved Materials List? N

Will this proposal improve:

Construction costs? N/A

Construction time? N/A

Customer satisfaction? N/A

Congestion/travel time? N/A

Ride quality? N/A

Will this proposal reduce operational costs or maintenance effort? N/A

Will this item improve safety:

For motorists? N/A

For construction workers? N/A

Will this proposal improve quality for:

Construction procedures/processes? N/A

Asset preservation? N/A

Design process? N/A

Will this change provide the contractor more flexibility? N/A

Will this proposal provide clarification for the Contractor and field personnel? Yes

Can this item improve/reduce the number of potential change orders? N/A

Is this proposal needed for compliance with:

Federal or State regulations? N

AASHTO or other design code? N

Is this item editorial? N

Provide any further information as to why this proposal should be placed on the Standards Committee meeting Agenda: N/A

REVISION TO SPECIAL PROVISION

501-R-752 INERTIAL PROFILER WITH SMOOTHNESS PAY ADJUSTMENTS FOR PCCP, FIXED INTERVAL

501-R-752 INERTIAL PROFILER WITH SMOOTHNESS PAY ADJUSTMENTS FOR PCCP,
FIXED INTERVAL

(Revised 08-18-22)

The Standard Specifications are revised as follows:

SECTION 501, DELETE LINES 409 THROUGH 514.

SECTION 501, AFTER LINE 514, INSERT AS FOLLOWS:

501.25 Pavement Smoothness

Pavement smoothness will be accepted by means of an inertial profiler, a 16 ft ~~long~~ straightedge, or a 10 ft ~~long~~ straightedge as described below.

(a) Inertial Profiler with Smoothness Pay Adjustments

When a pay item for Inertial Profiler, PCCP is included in the contract, the Contractor shall furnish, calibrate, and operate an approved inertial profiler in accordance with ITM 917 for the acceptance of longitudinal smoothness on the mainline traveled way, including adjacent acceleration or deceleration lanes, where both of the following conditions are met:

- 1. The posted speed is greater than 45 mph.*
- 2. The traveled way width and slope are constant and is at least 0.5 mi in length.*

The profiles and International Roughness Index, IRI, results including areas of localized roughness, ~~and fixed interval IRI results~~ shall become the property of the Department. The inertial profiler shall remain the property of the Contractor.

The project area will be divided into individual smoothness sections measuring 0.1 mi in length for each lane. The paving exceptions and areas exempt from inertial profiler operation will be in accordance with ITM 917.

If the posted speed limit for an entire smoothness section is less than or equal to 45 mph, the section will be exempt from ~~inertial~~ profiler operation and the smoothness within the section will be accepted in accordance with 501.25(b).

If the posted speed limit is greater than 45 mph for a portion of a smoothness section and is less than or equal to 45 mph for the remainder, the section smoothness acceptance will be as follows:

- 1. By inertial profiler for the portion of the section with a posted speed limit greater than 45 mph.*
- 2. In accordance with 501.25(b) for the portion of the section with a posted speed limit less than or equal to 45 mph.*

(b) 16 ft Straightedge

The Contractor shall furnish and operate a 16 ft straightedge in accordance with 306.03(d) and as described below. The 16 ft straightedge shall be used to measure smoothness along the direction of mainline traffic.

REVISION TO SPECIAL PROVISION

501-R-752 INERTIAL PROFILER WITH SMOOTHNESS PAY ADJUSTMENTS FOR PCCP, FIXED INTERVAL

Locations on the pavement surface scraped by the straightedge shall be marked. The pavement shall be corrected in accordance with 501.25(e) to meet the required tolerance. For existing utility and manhole castings that required no grade adjustment, the tolerance may be adjusted after being reviewed and approved by the Engineer.

For contracts which include the Inertial Profiler, PCCP pay item, the 16 ft ~~long~~ straightedge or the Inertial Profiler simulating the 16 ft ~~long~~ straightedge shall be used to measure longitudinal smoothness at the following locations:

- 1. All mainline traveled way lanes shorter than 0.5 mi.*
- 2. All mainline traveled way lanes at locations exempted from inertial profiler operation in accordance with ITM 917.*
- 3. All mainline traveled way lanes within smoothness sections with posted speed limits less than or equal to 45 mph throughout the entire section length.*
- 4. All tapers.*
- 5. All ramps.*
- 6. All turn lanes, including bi-directional left turn lanes shorter than 0.5 mi.*
- 7. All acceleration and deceleration lanes associated with ramps with posted speeds of 45 mph or less.*
- 8. All shoulders.*
- 9. All intersections with significant change in cross slope.*

For contracts where the inertial profiler is not used for smoothness acceptance, the 16 ft straightedge shall be used to measure longitudinal smoothness. Measurement with the 16 ft straightedge shall include ~~at~~ the above locations, ~~on~~ all mainline traveled way lanes and ramps with posted speeds greater than 45 mph, and on ramp acceleration or deceleration lanes.

(c) 10 ft Straightedge

The 10 ft straightedge will be in accordance with 306.03(d). The 10 ft straightedge will be used to check transverse slopes across travel lanes and shoulders, approaches, and crossovers. When the 10 ft straightedge is used, the pavement variations shall be corrected to 1/8 in. or less.

(d) Areas of Localized Roughness, ALR

At locations where the inertial profiler is used, all areas having a localized roughness in excess of 160 in./mi utilizing continuous IRI with a 25 ft window shall be corrected subject to approval by the Engineer. After ALRs have been identified, a grinding simulation shall be performed to estimate whether the ALR can be corrected to an IRI value of less than 160 in./mi with no more than a 1/4 in. maximum grind depth at any spot. If such correction is not possible, then an ALR with an IRI value of less than 190 in./mi can remain uncorrected if approved by the

REVISION TO SPECIAL PROVISION

501-R-752 INERTIAL PROFILER WITH SMOOTHNESS PAY ADJUSTMENTS FOR PCCP, FIXED INTERVAL

Engineer, and an ALR with an IRI value greater than 190 in./mi shall require full depth removal and replacement of sufficient area to meet specifications.

In addition, if there is only one ALR in any two-lane mile section, then no smoothness correction will be required if the ALR does not exceed 190 in./mi and the overall smoothness in accordance with 501.25(d) of the two-lane mile section does not require any corrective action. A two-lane mile section will start one mile before the ALR and end one mile after the ALR in order that all two-lane mile sections will have, at most, one ALR each.

(e) Smoothness Section Correction

Pavement smoothness variations outside specified tolerances shall be corrected by grinding with a groove type cutter or by replacement. Grinding will not be allowed until the PCCP is 10 days old and flexural strength testing yields a modulus of rupture of 550 psi or greater. The grinding of the pavement to correct the profile shall be accomplished in either the longitudinal or the transverse direction. The PCCP texture after grinding shall be uniform. If the grinding operation reduces the tining grooves to a depth of less than 1/16 in. and the longitudinal length of the removal area exceeds 15 ft, or two or more areas are within 30 ft of each other, the PCCP shall be re-textured in accordance with 504.03.

The width of the corrected area may be partial or full lane width, depending on the respective wheel path profiles. After the corrective action is complete, the inertial profiler shall be operated throughout the entire affected smoothness section to verify the adequacy of the corrective action.

At locations where the 16 ft straightedge is used, the pavement variations shall be corrected to 1/4 in. or less.

SECTION 501, DELETE LINES 632 THROUGH 657.

SECTION 501, AFTER LINE 657, INSERT AS FOLLOWS:

(d) Smoothness

Smoothness pay adjustments will only be applied when the smoothness is measured by an inertial profiler in accordance with 501.25(a).

~~When the pavement smoothness is tested with an inertial profiler, payment will be based on~~ The Mean Roughness Index, MRI, will be determined utilizing a fixed interval for each lane for each 0.1-mile section of paving. The MRI for a 0.1-mile section is the average of the IRI of the two-wheel paths. A Quality Assurance Pay Factor, PF_s , for smoothness will apply to the planned thickness of the PCCP. The quality assurance adjustment for each section will be calculated by the following formula:

$$q_s = (PF_s - 1.00) \times A \times U$$

where:

q_s = quality assurance adjustment for smoothness for one section

PF_s = pay factor for smoothness

A = area of the section, sq yd

U = unit price for the material, \$/sq yd.

REVISION TO SPECIAL PROVISION

501-R-752 INERTIAL PROFILER WITH SMOOTHNESS PAY ADJUSTMENTS FOR PCCP, FIXED INTERVAL

The quality assurance adjustment for smoothness, Q_s , for the contract will be the total of the quality assurance adjustments for smoothness, q_s , on each section by the following formula:

$$Q_s = \sum q_s$$

When smoothness is measured by an inertial profiler, payment adjustments will be made for any 0.1-mile section based on the initial MRI generated and in accordance with the following table. The MRI pay factors for smoothness will be determined prior to any required smoothness correction in accordance with 510.25(d). Smoothness correction if required shall be in accordance with 501.25(d). For any 0.1-mile sections containing transverse construction joints that are required as per the planned maintenance of traffic, the pay factors for smoothness may be determined after corrective action at the discretion of the Contractor. Regardless of the tabulated value, the maximum pay factor for a smoothness section where corrective action has been performed will be 1.00.

<i>PAY FACTORS FOR SMOOTHNESS</i>	
<i>Posted Speed greater than 45 mph</i>	
<i>MRI, in./mi</i>	<i>Pay Factor, PF_s</i>
<i>over 0 to 35</i>	<i>1.08</i>
<i>over 35 to 40</i>	<i>1.07</i>
<i>over 40 to 45</i>	<i>1.05</i>
<i>over 45 to 50</i>	<i>1.03</i>
<i>over 50 to 55</i>	<i>1.02</i>
<i>over 55 to 60</i>	<i>1.01</i>
<i>over 60 to 70</i>	<i>1.00</i>
<i>over 70 to 75</i>	<i>0.99</i>
<i>over 75 to 80</i>	<i>0.98</i>
<i>over 80 to 85</i>	<i>0.96</i>
<i>over 85 to 90</i>	<i>0.95</i>
<i>over 90</i>	<i>PF_s will be 0.95 and the section shall be corrected to 90 or less.</i>

SECTION 501, BEGIN LINE 658, DELETE AND INSERT AS FOLLOWS:

501.29 Appeals

(a) PCCP Materials

If the Contractor does not agree with the acceptance test results, a request may be made in writing for additional tests for a subplot or lot. The basis of the appeal shall include applicable QC test results showing acceptable quality results and shall be submitted within five calendar days of receipt of the Department's written results for that lot. Upon review of the appeal, the Engineer may accept the PCCP in accordance with 105.03 or accept the appeal.

(a)1. Modulus of Rupture

SECTION 501, BEGIN LINE 693, DELETE AND INSERT AS FOLLOWS:

(b)2. Air Content

SECTION 501, AFTER LINE 708, INSERT AS FOLLOWS:

(b) Smoothness

REVISION TO SPECIAL PROVISION

501-R-752 INERTIAL PROFILER WITH SMOOTHNESS PAY ADJUSTMENTS FOR PCCP, FIXED INTERVAL

The Department will perform annual Quality Assurance reviews of a portion of each Contractor’s MRI results in accordance with ITM 917. The Contractor’s results will be compared to the Department’s. The Department will notify the Contractor of unacceptable results in a timely manner. The Department will allow an appeal period of 14 days during which time the Contractor must submit a written request and appeal results for Department review. If the Contractor’s appeal results do not agree with the Department’s results, the Contractor shall be required to perform a side-by-side evaluation. The Department’s results will be utilized for smoothness payment in place of the Contractor’s results unless the Contractor’s appeal results are determined to be acceptable for payment. Sections where corrective action has taken place prior to the Department’s data collection will utilize the Contractor’s initial results prior to corrective action for payment.

SECTION 501, BEGIN LINE 719, DELETE AND INSERT AS FOLLOWS:

501.31 Basis of Payment

The accepted quantities of QC/QA-PCCP will be paid for at the contract unit price per square yard for the thickness specified, complete in place.

[statement “Furnishing...” moved below]

Payment for furnishing, calibrating, and operating the ~~profilograph~~ *inertial profiler*, and furnishing *IRI* profile information will be made at the contract lump sum price for ~~profilograph~~ *Inertial Profiler, PCCP*.

[moved here] *Furnishing and operating the 16 ft straightedge shall be included in the cost of other pay items within this section.*

SECTION 501, BEGIN LINE 746, DELETE AND INSERT AS FOLLOWS:

~~Profilograph~~ *Inertial Profiler, PCCP*LS

SECTION 501, BEGIN LINE 752, DELETE AND INSERT AS FOLLOWS:

The price of ~~profilograph~~ *Inertial Profiler, PCCP* will be full compensation regardless of how often the ~~profilograph~~ *inertial profiler* is used or how ~~many profilograms are produced~~ often the *IRI* is determined.

SECTION 502, BEGIN LINE 358, DELETE AND INSERT AS FOLLOWS:

502.20 Pavement Smoothness

Pavement smoothness will be in accordance with 501.25 except ~~profilograph~~ *inertial profiler* requirements will not apply.

COMMENTS AND ACTION

501-R-752 INERTIAL PROFILER WITH SMOOTHNESS PAY ADJUSTMENTS FOR PCCP, FIXED INTERVAL

DISCUSSION:

This item was introduced and presented by Mr. Hauser, sitting in as proxy for Mr. Novak, assisted by Mr. Blanchard who explained that in preparation for the conversion from profilograph to high-speed inertial profilers in 2023, INDOT has been working with FHWA to establish QA program requirements. This QA is required because the Contractor’s data is used as the basis for acceptance and payment. The current specification does not include program level QA requirements.

Mr. Hauser proposed to add program level QA requirements to the spec. Also, some editorial changes are proposed, as shown.

There was no further discussion and this item passed as submitted.

	<u>Action:</u>
Motion: Mr. Hauser Second: Mr. Koch Ayes: 9 Nays: 0 FHWA Approval: Yes	<input checked="" type="checkbox"/> Passed as Submitted <input type="checkbox"/> Passed as Revised <input type="checkbox"/> Withdrawn
2022 Standard Specifications Sections referenced and/or affected: 501.29, begin pg 419.	<input checked="" type="checkbox"/> 2024 Standard Specifications <input type="checkbox"/> Revise Pay Items List <input type="checkbox"/> Create RSP (No. __) Effective:
Recurring Special Provisions or Plan Details: 501-R-752 INERTIAL PROFILER WITH SMOOTHNESS PAY ADJUSTMENTS FOR PCCP, FIXED INTERVAL	<input checked="" type="checkbox"/> Revise RSP (No. <u>501-R-752</u>) Effective: <u>June 1, 2023</u>
Standard Drawing affected: NONE	<input type="checkbox"/> Standard Drawing Effective:
Design Manual Sections affected: NONE	<input type="checkbox"/> Create RPD (No. __) Effective:
GIFE Sections cross-references: 5.16, 8.13, 13.4, 13.17	<input checked="" type="checkbox"/> GIFE Update <input type="checkbox"/> Frequency Manual Update <input type="checkbox"/> SiteManager Update

PROPOSAL TO STANDARDS COMMITTEE

PROBLEM(S) ENCOUNTERED: A statement exists in the 507 PCCP Restoration basis of payment section that should have been deleted in December 2020 when the option to use HMA for partial depth patching was deleted.

PROPOSED SOLUTION: Delete the now irrelevant statement.

APPLICABLE STANDARD SPECIFICATIONS: 507

APPLICABLE STANDARD DRAWINGS: None

APPLICABLE DESIGN MANUAL SECTION: None

APPLICABLE SECTION OF GIFE: None

APPLICABLE RECURRING SPECIAL PROVISIONS: None

PAY ITEMS AFFECTED: None

APPLICABLE SUB-COMMITTEE ENDORSEMENT: Ad Hoc: Mike Koch, Jim Reilman

IF APPROVED AS RECURRING SPECIAL PROVISION OR PLAN DETAILS, PROPOSED BASIS FOR USE: N/A

IMPACT ANALYSIS (attach report):

Submitted By: Jim Reilman

Title: State Materials Engineer

Organization: INDOT

Phone Number: (317) 522-9692

Date: 10/21/22

IMPACT ANALYSIS REPORT CHECKLIST

Explain the business case as to why this item should be presented to the Standards Committee for approval. Answer the following questions with Yes, No or N/A.

Does this item appear in any other specification sections? No

Will approval of this item affect the Approved Materials List? No

Will this proposal improve:

Construction costs? N/A

Construction time? N/A

Customer satisfaction? N/A

Congestion/travel time? N/A

Ride quality? N/A

Will this proposal reduce operational costs or maintenance effort? N/A

Will this item improve safety:

For motorists? N/A

For construction workers? N/A

Will this proposal improve quality for:

Construction procedures/processes? N/A

Asset preservation? N/A

Design process? N/A

Will this change provide the contractor more flexibility? N/A

Will this proposal provide clarification for the Contractor and field personnel? Yes

Can this item improve/reduce the number of potential change orders? N/A

Is this proposal needed for compliance with:

Federal or State regulations? No

AASHTO or other design code? No

Is this item editorial? Yes

Provide any further information as to why this proposal should be placed on the Standards Committee meeting Agenda:

REVISION TO 2022 STANDARD SPECIFICATIONS

SECTION 507 – PCCP RESTORATION

507.10 Basis of Payment

The Standard Specifications are revised as follows:

SECTION 507, BEGIN LINE 176, DELETE AS FOLLOWS:

507.10 Basis of Payment

Routing and sealing of cracks, filling of cracks, sawing and sealing of joints and filling of joints will be paid for by the linear foot, complete in place. The accepted quantities of retrofit load transfer will be paid for at the contract unit price per each assembly installed, complete in place. PCCP patching will be paid for in accordance with 506.14. PCCP joint repair will be paid for in accordance with 509.19. Profiling will be paid for by the square yard. Undersealing and drilled holes will be paid for in accordance with 612.08.

The cost of temporary traffic control measures for routing, sealing or filling of cracks or joints, and profiling will be paid for in accordance with 801.18.

Payment will be made under:

Pay Item	Pay Unit Symbol
Cracks in PCCP, Filled	LFT
Cracks in PCCP, Rout and Seal	LFT
Joints in PCCP, Filled	LFT
Joints in PCCP, Saw and Seal	LFT
Profiling PCCP	SYS
Retrofit Load Transfer.....	EACH

~~The cost of milling, cleaning, tacking, and all incidentals shall be included in the cost of the pay item, partial depth patching.~~

The cost of cutting of slots, cleaning, dowel bars, dowel bar supports, dowel bar end caps, foam board, mortar, and curing materials shall be included in the cost of the pay item retrofit load transfer.

COMMENTS AND ACTION

507.10 Basis of Payment

DISCUSSION:

Mr. Reilman introduced and presented this item stating that a statement exists in the 507 PCCP Restoration basis of payment section that should have been deleted in December 2020 when the option to use HMA for partial depth patching was deleted.

Mr. Reilman proposed to delete the now irrelevant statement, as shown above.

There was no further discussion and this item passed as submitted.

<p>Motion: Mr. Reilman Second: Mr. Dave Ayes: 9 Nays: 0 FHWA Approval: Yes</p>	<p><u>Action:</u> <input checked="" type="checkbox"/> Passed as Submitted <input type="checkbox"/> Passed as Revised <input type="checkbox"/> Withdrawn</p>
<p>2022 Standard Specifications Sections referenced and/or affected: 507.10 pg 463.</p> <p>Recurring Special Provisions or Plan Details: NONE</p> <p>Standard Drawing affected: NONE</p> <p>Design Manual Sections affected: NONE</p> <p>GIFE Sections cross-references: NONE</p>	<p><input checked="" type="checkbox"/> 2024 Standard Specifications Revise Pay Items List</p> <p><input type="checkbox"/> Create RSP (No. __) Effective:</p> <p><input type="checkbox"/> Revise RSP (No. __) Effective:</p> <p><input type="checkbox"/> Standard Drawing Effective:</p> <p><input type="checkbox"/> Create RPD (No. __) Effective:</p> <p><input type="checkbox"/> GIFE Update <input type="checkbox"/> Frequency Manual Update <input type="checkbox"/> SiteManager Update</p>

PROPOSAL TO STANDARDS COMMITTEE

PROBLEM(S) ENCOUNTERED: Unneeded terminology and awkward phrasing exists in the 700 section.

PROPOSED SOLUTION: Clean up the 700 section by incorporating the proposed changes into the 2024 spec book.

APPLICABLE STANDARD SPECIFICATIONS: 702, 706, 715, 716, 722, 725, and 734

APPLICABLE STANDARD DRAWINGS: None

APPLICABLE DESIGN MANUAL SECTION: None

APPLICABLE SECTION OF GIFE: None

APPLICABLE RECURRING SPECIAL PROVISIONS: None

PAY ITEMS AFFECTED: None

APPLICABLE SUB-COMMITTEE ENDORSEMENT: Ad hoc: Kurt Pelz, Lana Podorvanova, Jim Reilman, Scott Trammell

IF APPROVED AS RECURRING SPECIAL PROVISION OR PLAN DETAILS, PROPOSED BASIS FOR USE: N/A

IMPACT ANALYSIS (attach report):

Submitted By: Jim Reilman

Title: State Materials Engineer

Organization: INDOT

Phone Number: (317) 522-9692

Date: 9/12/22

IMPACT ANALYSIS REPORT CHECKLIST

Explain the business case as to why this item should be presented to the Standards Committee for approval. Answer the following questions with Yes, No or N/A.

Does this item appear in any other specification sections? No

Will approval of this item affect the Approved Materials List? No

Will this proposal improve:

Construction costs? N/A

Construction time? N/A

Customer satisfaction? N/A

Congestion/travel time? N/A

Ride quality? N/A

Will this proposal reduce operational costs or maintenance effort? N/A

Will this item improve safety:

For motorists? N/A

For construction workers? N/A

Will this proposal improve quality for:

Construction procedures/processes? Yes

Asset preservation? N/A

Design process? Yes

Will this change provide the contractor more flexibility? N/A

Will this proposal provide clarification for the Contractor and field personnel? Yes

Can this item improve/reduce the number of potential change orders? Yes

Is this proposal needed for compliance with:

Federal or State regulations? No

AASHTO or other design code? No

Is this item editorial? No

Provide any further information as to why this proposal should be placed on the Standards Committee meeting Agenda:

REVISION TO 2022 STANDARD SPECIFICATIONS

DIVISION 700 – STRUCTURES (*various sections*)

The Standard Specifications are revised as follows:

SECTION 702, BEGIN LINE 298, DELETE AS FOLLOWS:

702.09 Ready-Mixed Concrete

(a) General Requirements

Ready-mixed concrete shall be mixed and delivered by means of one of the following operations:

1. Mixed completely in a stationary mixer and the mixed concrete transported to the point of delivery in a truck-agitator or truck-mixer at agitating speed or in ~~approved~~ non-agitating equipment in accordance with 702.09(d). Concrete delivered under these provisions shall be known as central-mixed concrete.

SECTION 702, BEGIN LINE 1223, DELETE AND INSERT AS FOLLOWS:

[702.22(a) Protective Covering Curing Method]

2. Membrane Forming Curing Compound

All surfaces shall be given the required surface finish prior to application of the curing compound. During the finishing period, the concrete shall be protected by the water curing method.

The curing compound shall be mixed thoroughly within 1 h before use. The ~~rate of~~ application shall be ~~as approved, with~~ a minimum spreading rate ~~per application~~ of 1 gal. of liquid coating for *every* 150 sq ft of concrete surface. Curing compound shall be applied to provide a uniform, solid, white opaque coverage on all surfaces, similar to a white sheet of paper. All concrete cured by this method shall receive two applications of the curing compound. The first ~~coat~~ *application* shall be applied immediately after stripping of forms and acceptance of the concrete finish. If the surface is dry, the concrete shall be wetted with water and the curing compound applied just as the surface film of water disappears. The second application shall be applied after the first application has set. During curing operations all unsprayed surfaces shall be kept wet with water.

SECTION 706, BEGIN LINE 50, DELETE AND INSERT AS FOLLOWS:

[706.03 Concrete Railing]

Unless otherwise specified the slip form method may be used as a means to place concrete railing on bridge structures. If the slip form method is chosen, a signed and dated QCP shall be prepared and submitted to the Engineer for acceptance at least 15 days prior to the start of slip form barrier rail placement. The QCP shall include, as a minimum, the Contractor's concrete mix design, including materials sources and admixtures; the Contractor's methods of materials control and testing; the Contractor's proposed method of placement, including *ensuring proper consolidation around reinforcing bars*, finishing, and curing; and the corrective action that will be taken when defects are found. ~~The QCP shall also contain documentation that shows the Contractor had a successful trial demonstration of the slip form machine previously and that proper consolidation around the reinforcing bars in the wall was achieved.~~ The slip form paver shall consolidate, screed,

REVISION TO 2022 STANDARD SPECIFICATIONS

DIVISION 700 – STRUCTURES (*various sections*)

and finish the freshly placed concrete in one complete pass in such a manner that a minimum of hand finishing will be necessary to provide a dense and homogeneous railing in conformance with the plans and specifications. ~~The requirement to include a water-reducing admixture in accordance with 702.05 will be waived if the railing is both slipformed and the concrete contains silica fume in accordance with 709.05(e).~~ **[approved by SC on 12/17/2021 meeting. RSP 702-R-739]** The slump shall be 1 3/4 in. \pm 3/4 in. The joints may be formed or sawed as long as a satisfactory joint is attained. If joints are to be sawed, the full depth saw cut shall be made before uncontrolled shrinkage cracking occurs and within 48 h of concrete placement. Before full depth sawing, partial depth saw cuts of 2 1/2 in. \pm 1/2 in. at the joint locations may be made as soon as the concrete has hardened sufficiently to enable sawing without raveling. All saw cuts shall be made at the locations shown on the plans or as directed.

SECTION 715, BEGIN LINE 450, DELETE AS FOLLOWS:

[715.12 Pavement Replacement]

The pavement replacement areas in asphalt pavements shall be filled with HMA for Structure Installation of the mixture type specified in the pay item in accordance with 402 except OG mixtures shall be in accordance with 401.05. An MAF in accordance with 402.05 will not apply. Mixtures will be accepted in accordance with 402.09. Each course shall be compacted by ~~approved~~ mechanical equipment in accordance with 409.03(d).

SECTION 716, BEGIN LINE 109, DELETE AS FOLLOWS:

716.03 General Requirements

The Contractor shall submit a ~~Quality Control Plan, QCP~~, in accordance with ITM 803. The QCP shall be submitted to the Engineer for review and acceptance, at least 15 days prior to the start of trenchless pipe installation operations.

SECTION 722, BEGIN LINE 10, DELETE AND INSERT AS FOLLOWS:

722.02 Quality Control

LMC-VE overlays shall be placed in accordance with the QCP, which shall be prepared and submitted in accordance with ITM 803. The QCP shall include the Contractor's experience placing LMC-VE overlays within the last three years. The QCP shall be submitted to the Engineer at least 14 days prior to commencing *the* overlay operations. ~~Approval of the QCP by the Department's Division of Materials and Tests is required. Work shall not begin until written notice has been received that the QCP was accepted by the Department's Division of Materials and Tests.~~

SECTION 725, BEGIN LINE 126, DELETE AS FOLLOWS:

[725.06(b) Solid Wall HDPE Liner Pipe]

Solid wall HDPE liner pipe that is to have extrusion welded joints shall have destructive testing performed on a test section of liner pipe of the same material as the liner pipe being installed. The Contractor shall propose and describe in the QCP a destructive test, such as but not limited to a bend strap test, to demonstrate that an operator can produce an extrusion welded joint that will not fail. Once an extrusion welded joint is produced on a test section that passes the destructive test, each subsequent joint fabricated that same day by that operator will be visually inspected for acceptance. A destructive test in accordance

REVISION TO 2022 STANDARD SPECIFICATIONS

DIVISION 700 – STRUCTURES (*various sections*)

with the approved QCP shall be conducted on the test section at the beginning of each day that solid wall HDPE liner pipe joining is being done.

(c) Profile Wall HDPE Liner Pipe

Profile Wall HDPE liner pipe joined using extrusion welding shall be in accordance with ASTM F894. The Contractor shall propose and describe in the QCP a destructive test, such as but not limited to a bend strap test, to demonstrate that an operator can produce an extrusion welded joint that will not fail. Destructive testing shall be performed on two flat pieces of HDPE sheet stock that has been butt welded together to verify the extrusion gun is working properly and that the operator can produce an extrusion welded joint that will not fail. Once an extrusion welded joint is produced on a test section that passes the destructive test, each subsequent joint fabricated that same day by that operator will be visually inspected for acceptance. A destructive test in accordance with the approved QCP shall be conducted on the test section at the beginning of each day that profile wall HDPE liner pipe joining is being done.

SECTION 734, BEGIN LINE 174, DELETE AS FOLLOWS:

[734.02(c) Submittals]

At least 30 calendar days before the start of the wall construction, the Contractor shall submit a ~~quality control plan~~, QCP, which will be subject to approval. The QCP shall include, but not be limited to, personnel qualifications, wall construction procedures and sequencing, a verification testing program, and a performance monitoring program. Work shall not begin until written notice has been received from the Engineer that the QCP has been accepted.

COMMENTS AND ACTION

DIVISION 700 – STRUCTURES (*various sections*)

DISCUSSION:

This item was introduced and presented by Mr. Reilman who stated that unneeded terminology and awkward phrasing exists in the 700 section.

Mr. Reilman proposed to clean up the 700 section by incorporating the proposed changes into the 2024 spec book.

There was no further discussion and this item passed as submitted.

<p>Motion: Mr. Reilman Second: Mr. White Ayes: 9 Nays: 0 FHWA Approval: Yes</p>	<p><u>Action:</u> <input checked="" type="checkbox"/> Passed as Submitted <input type="checkbox"/> Passed as Revised <input type="checkbox"/> Withdrawn</p>
<p>2022 Standard Specifications Sections referenced and/or affected: 702 pg 625, 645; 706 pg 660; 715 pg 741; 716 pg 749; 722 pg 769; 725 pg 809; 734 pg 852.</p> <p>Recurring Special Provisions or Plan Details: 702-R-739 STRUCTURAL CONCRETE AND USE OF OPTIMIZED AGGREGATE GRADATION IN CONCRETE</p> <p>Standard Drawing affected: NONE</p> <p>Design Manual Sections affected: NONE</p> <p>GIFE Sections cross-references: NONE</p>	<p><input checked="" type="checkbox"/> 2024 Standard Specifications Revise Pay Items List</p> <p><input type="checkbox"/> Create RSP (No. __) Effective:</p> <p><input type="checkbox"/> Revise RSP (No. __) Effective:</p> <p><input type="checkbox"/> Standard Drawing Effective:</p> <p><input type="checkbox"/> Create RPD (No. __) Effective:</p> <p><input type="checkbox"/> GIFE Update <input type="checkbox"/> Frequency Manual Update <input type="checkbox"/> SiteManager Update</p>

PROPOSAL TO STANDARDS COMMITTEE

PROBLEM(S) ENCOUNTERED: Inconsistent terminology and punctuation in 707 is creating confusion.

PROPOSED SOLUTION: Clean up 707; it is describing two products: precast concrete structural members and precast prestressed concrete structural members. This proposal standardizes the terminology and clears up confusion by removing a comma inserted between precast and prestressed (...precast, prestressed...) beginning with the 2022 spec book.

APPLICABLE STANDARD SPECIFICATIONS: 707

APPLICABLE STANDARD DRAWINGS: None

APPLICABLE DESIGN MANUAL SECTION: None

APPLICABLE SECTION OF GIFE:

APPLICABLE RECURRING SPECIAL PROVISIONS: None

PAY ITEMS AFFECTED: None

APPLICABLE SUB-COMMITTEE ENDORSEMENT: Ad hoc: Jon Korff, Mike Nelson, Jim Reilman

IF APPROVED AS RECURRING SPECIAL PROVISION OR PLAN DETAILS, PROPOSED BASIS FOR USE:
N/A

IMPACT ANALYSIS (attach report):

Submitted By: Jim Reilman

Title: State Materials Engineer

Organization: INDOT

Phone Number: (317) 522-9692

Date: 10/21/22

IMPACT ANALYSIS REPORT CHECKLIST

Explain the business case as to why this item should be presented to the Standards Committee for approval. Answer the following questions with Yes, No or N/A.

Does this item appear in any other specification sections? No

Will approval of this item affect the Approved Materials List? No

Will this proposal improve:

Construction costs? N/A

Construction time? N/A

Customer satisfaction? N/A

Congestion/travel time? N/A

Ride quality? N/A

Will this proposal reduce operational costs or maintenance effort? N/A

Will this item improve safety:

For motorists? N/A

For construction workers? N/A

Will this proposal improve quality for:

Construction procedures/processes? Yes

Asset preservation? N/A

Design process? Yes

Will this change provide the contractor more flexibility? N/A

Will this proposal provide clarification for the Contractor and field personnel? Yes

Can this item improve/reduce the number of potential change orders? Yes

Is this proposal needed for compliance with:

Federal or State regulations? No

AASHTO or other design code? No

Is this item editorial? No

Provide any further information as to why this proposal should be placed on the Standards Committee meeting Agenda:

REVISION TO 2022 STANDARD SPECIFICATIONS

SECTION 707 – PRECAST AND PRECAST, PRESTRESSED CONCRETE STRUCTURAL MEMBERS (*various sections*)

The Standard Specifications are revised as follows:

SECTION 707, BEGIN LINE 1, DELETE AND INSERT AS FOLLOWS:

**SECTION 707 – PRECAST *CONCRETE* AND PRECAST, PRESTRESSED
CONCRETE STRUCTURAL MEMBERS**

707.01 Description

This work shall consist of fabricating, furnishing, and installing reinforced precast concrete structural members cast outside the structure, transported to, and incorporated into the structure, or precast, prestressed concrete structural members having a design 28-day concrete compressive strength, f'_c , of up to and including 8,000 psi, all in accordance with 105.03.

SECTION 707, BEGIN LINE 38, DELETE AND INSERT AS FOLLOWS:

All precast, ~~non-prestressed~~ concrete structural members *which are not prestressed* shall be manufactured by a precast concrete producer from the QPL of Certified Precast Concrete Producers. All precast, prestressed *concrete* structural members including, but not limited to concrete box-beams, I-beams, U-beams, and bulb-T beams shall be manufactured by a precast prestressed concrete producer from the QPL of Certified Precast Prestressed Concrete Producers.

SECTION 707, BEGIN LINE 60, DELETE AND INSERT AS FOLLOWS:

Prior to the beginning of fabrication, a prefabrication meeting shall be held at the fabrication facility or another agreed upon location. The meeting shall be conducted by the Contractor and attended by the fabricator's production supervisor and ~~quality control~~ QC inspector, and the Engineer. The Contractor shall take notes of the meeting and distribute copies to all attending parties within five days of the date of the meeting. Items to be discussed at the meeting shall include a minimum of: fabrication and shipping schedule including hours of operation; line of communication between the Contractor and the Engineer; material test reports; working drawings; special fabrication methods; and fabrication hold points for inspection; final inspection and acceptance of materials; method of shipment. The requirement to hold prefabrication meetings may be waived by the Department.

A type A field office in accordance with 628 shall be provided at any facility that fabricates precast, prestressed *concrete* structural members for the Department's exclusive use. In lieu of a field office, a work area and the following items in accordance with 628 for the exclusive use by the Department shall be provided on the property where the structural members are being fabricated.

- (a) office desktop
- (b) office chair
- (c) broadband internet service
- (d) telephone
- ~~(e) fax machine~~
- (fe) copier

REVISION TO 2022 STANDARD SPECIFICATIONS

SECTION 707 – PRECAST AND PRECAST, PRESTRESSED CONCRETE STRUCTURAL MEMBERS (*various sections*)

(gf) filing cabinet.

707.04 Steel and Concrete Requirements

(a) Reinforcing Bars

A tight coat of concrete grout extending 1/2 in. maximum from the top of precast *concrete* and precast, prestressed concrete structural members will be allowed to remain on reinforcing bars extending from precast *concrete* and precast, prestressed *concrete* structural members. All loose and flaky material on these reinforcing bars shall be removed. Lap splices shall be in accordance with 703.06.

SECTION 707, AFTER LINE 140, INSERT AS FOLLOWS:

1. Self-Consolidating Concrete, SCC

SCC may be used in precast prestressed concrete structural members.

SECTION 707, BEGIN LINE 149, DELETE AND INSERT AS FOLLOWS:

34. Acceptance Testing

Acceptance of precast *concrete* and precast, prestressed *concrete* structural members will be based on *the following tests for slump, air content, and compressive strength in accordance with the Frequency Manual*. All ~~slump, air content, and compressive strength~~ tests shall be performed in the presence of the Engineer. *For conventional concrete slump, and air content, and compressive strength tests measurements shall be performed obtained each time cylinders are made. For SCC slump flow, air content, relative viscosity, visual stability index, and compressive strength tests shall be performed.* Compressive strengths of the structural members shall be determined from cylinder sets described herein. The 28-day compressive strength shall be equal to or greater than the specified concrete compressive strength. The compressive strength of the concrete for each structural member will be determined from the average strength of the cylinder set representing that member. No individual strength within a cylinder set representing a structural member shall be less than 90% of the specified concrete compressive strength.

SECTION 707, BEGIN LINE 193, DELETE AND INSERT AS FOLLOWS:

b. Precast, Non-Prestressed Concrete Structural Members

When fabricating precast, ~~non-prestressed~~ *concrete* structural members *which are not prestressed, a minimum of one cylinder set shall be made per member east the number of cylinder sets shall be cast in accordance with the Frequency Manual*. The 28-day compressive strength of the concrete for each structural member will be determined by the average strength of the cylinder set representing that member. The fabricator may elect to make additional cylinder sets for use in acceptance testing prior to 28 days.

c. Precast, Prestressed Concrete Structural Members

~~A minimum of two cylinder sets shall be made for each structural member east.~~ *Cylinder sets shall be cast in accordance with the Frequency Manual*. One cylinder set shall be tested and used to determine when the precast, prestressed *concrete* structural member has met or exceeded the required strength for detensioning the prestressing bed. If an additional cylinder set as described above has been made, the Contractor may test this

REVISION TO 2022 STANDARD SPECIFICATIONS

SECTION 707 – PRECAST AND PRECAST, PRESTRESSED CONCRETE STRUCTURAL MEMBERS (*various sections*)

set to determine if the required strength for detensioning of the prestressing bed has been met or exceeded, or if the required 28-day compressive strength has been met or exceeded prior to an age of 28 days. The Engineer will accept the results from the compression testing on the additional cylinder set, in place of either the detensioning strength test results, or the 28-day compressive strength test results, if the results equal or exceed the respective compressive strength requirements. If an additional cylinder set was not made, or if the additional cylinder set does not meet or exceed the 28-day compressive strength requirement, the remaining cylinder set shall be tested at 28 days of age to determine the acceptability of the structural members.

Coring of precast, prestressed *concrete* structural members shall not be performed. Precast, prestressed *concrete* structural members that have been cored will not be accepted. Compressive strength results for cylinders that exceed 28 days in age or results from cylinders that do not have the Department-marked cylinder identification tag intact will result in the structural members not being accepted.

(d) Other Requirements

Precast concrete structural members which are not prestressed shall have a minimum compressive strength of 4,500 psi in 28 days.

[moved to a separate paragraph] Precast, prestressed *concrete* structural members shall be in accordance with the following unless otherwise shown on the plans:

SECTION 707, BEGIN LINE 239, DELETE AND INSERT AS FOLLOWS:

Inspection of the precast, prestressed *concrete* structural members during manufacturing and checking and testing aggregates, cement, concrete, and steel specimens shall be performed. All specimens shall be furnished without cost to the Department. Inspection, checking, and testing performed by the Department will not relieve the Contractor or the fabricator from performing their own ~~quality control~~ QC inspection, testing, and checking as necessary to maintain ~~quality control~~ QC over the manufacturing, handling, and curing procedure. A permanent record of the force applied to and measured elongation obtained for each prestressing strand shall be provided. The record shall also identify the strand and structural member to which the record applies. The accuracy of this record shall be certified by the fabricator's production supervisor that it accurately represents the force applied and measured elongation. The certified record shall be provided to the Engineer prior to shipment.

SECTION 707, BEGIN LINE 300, DELETE AND INSERT AS FOLLOWS:

707.07 Removal of Forms and Curing

Curing shall be in an enclosure designed to minimize heat and moisture loss. Insulated blankets may be used. The concrete in the form shall be maintained at a minimum temperature of 50°F during the entire curing cycle. Curing for precast *concrete* or precast, prestressed *concrete* structural members shall be done by wet curing without supplemental heat or by accelerated curing. During the period of initial set of the structural member and during the accelerated curing by radiant heat, the concrete shall be kept wet by the method outlined below for wet curing without supplemental heat.

REVISION TO 2022 STANDARD SPECIFICATIONS

SECTION 707 – PRECAST AND PRECAST, PRESTRESSED CONCRETE STRUCTURAL MEMBERS (*various sections*)

Approval shall be obtained before curing is done by any means other than those outlined below.

Side forms may be removed when no distortion, slump, or misalignment of the concrete will result. Precast *concrete* structural members which are not prestressed shall remain on the bottom supporting forms for the span until the concrete has reached a strength of at least 2,000 psi as evidenced by cylinders sets made and cured in the same manner as the slab.

(a) Wet Curing without Supplemental Heat

When wet curing without supplemental heat is used, the exposed surfaces of the structural members shall be covered by two layers of wet burlap and the burlap shall be kept wet to ensure that free water is present at all times. In lieu of using wet burlap, the Contractor may propose an alternate method which provides a moist environment with free water being present at all times. Written approval from the Engineer will be required prior to use of the proposed alternate method. Additional curing of precast *concrete* or precast, prestressed *concrete* structural members will not be required provided the minimum specified ultimate strength can be obtained.

In precast, prestressed concrete structural members, wet curing without supplemental heat shall continue until such time as the compressive strength of the concrete reaches or exceeds the strength specified for transfer of prestress or detensioning. At this point wet curing is considered to have concluded. Detensioning shall be performed within 6 h after wet curing has concluded.

[moved to a separate paragraph] In precast, ~~non-prestressed~~ *concrete* structural members which are not prestressed, wet curing without supplemental heat shall continue until such time as the compressive strength of the concrete reaches the strength specified for stripping of forms.

SECTION 707, BEGIN LINE 381, DELETE AND INSERT AS FOLLOWS:

When multiple structural members are cast in the same bed, all members shall meet or exceed the specified release strength prior to detensioning. Additional curing of precast *concrete* or precast, prestressed *concrete* structural members will not be required provided the minimum specified ultimate strength can be obtained.

SECTION 707, BEGIN LINE 395, DELETE AND INSERT AS FOLLOWS:

707.08 Handling and Shipping

Precast *concrete* and precast, prestressed *concrete* structural members shall not be subjected to excessive abuse which produces crushing or undue marring of the concrete. All structural members damaged during handling, storing, transporting, or erecting shall be replaced. Unless otherwise approved, precast *concrete* and precast, prestressed *concrete* structural members shall be handled with a suitable hoisting device provided with a spreader sling. The spreader shall be of sufficient length to prevent horizontal forces being produced in the structural member due to lifting and shall be equipped with leads and hooks

REVISION TO 2022 STANDARD SPECIFICATIONS

SECTION 707 – PRECAST AND PRECAST, PRESTRESSED CONCRETE STRUCTURAL MEMBERS (*various sections*)

at each end. *Unless otherwise shown on the contract plans, the location of the lifting points along the tops of the beams shall be in accordance with the transportation support point requirements given herein. If any other method of handling is used, it shall be shown on the working drawings. If the method produces horizontal forces in the precast or precast prestressed structural member, design calculations shall be submitted showing resulting stresses. The design of the structural members shall be satisfactory to handle these stresses in accordance with AASHTO LRFD Bridge Design Specifications.* The structural members shall be lifted by the devices and procedures shown on the ~~plans~~ *working drawings. Proposed alternate lifting devices and procedures shall be approved prior to use and shown on the working drawings. If any other method of handling is used, it shall be shown on the working drawings and approved prior to use. If the method produces horizontal forces in the precast or precast prestressed structural member, sufficient reinforcement shall be added to compensate for them.*

SECTION 707, BEGIN LINE 419, DELETE AND INSERT AS FOLLOWS:

Precast *concrete* structural members shall not be *lifted*, shipped or used until the concrete compressive strength reaches a minimum of 4,500 psi for members which are not prestressed and 5,000 psi for members which are prestressed.

SECTION 707, BEGIN LINE 435, DELETE AND INSERT AS FOLLOWS:

707.09 Placing Structural Members

If the method of lifting the structural members in the field differs from the method shown on the beam fabrication working drawings, the Contractor shall submit working drawings and calculations in accordance with 707.08. Erection of precast, prestressed *concrete* structural members shall commence at the centerline and proceed out to the curb, one member at a time. As each structural member is placed, the transverse tie bars, if shown on the plans, shall be inserted and secured. Any shifting of the structural members shall be done while they are held free of the supports by the hoisting device. The use of a steel pinch bar will not be allowed. Structural members shall be set to proper line and grade with uniform bearing on bridge seats, mortar joints, or bearing pads as required on the plans. When required, structural members shall be secured to the pier or bent with dowel rods. Holes for dowels shall be filled with mortar at fixed ends and with crack or joint filler at expansion ends. Longitudinal keyway joints shall be cleaned. A coat of cement mortar shall be scrubbed on the surface. The joint shall be filled with a non-shrinking grout composed of 1 part portland cement, 2 parts No. 23 fine aggregate, and an approved non-shrinking additive or a non-shrink, non-metallic cementation grout in accordance with ASTM C1107. All bolts or drains shown on the plans as necessary or desirable to be placed in the concrete shall be placed by the methods and at the locations shown on the plans. Necessary tie rods, tie bolts, and hardware for tying structural members together shall be furnished.

SECTION 707, BEGIN LINE 461, DELETE AND INSERT AS FOLLOWS:

Railing, when required, shall be of the type shown on the plans. The component parts shall be in accordance with 706, unless otherwise indicated on the plans. Other precast *concrete* or precast, prestressed *concrete* structural members shall be placed in the structure in accordance with the plans and the specifications or special provisions indicated for the type of structure being built.

REVISION TO 2022 STANDARD SPECIFICATIONS

SECTION 707 – PRECAST AND PRECAST, PRESTRESSED CONCRETE STRUCTURAL MEMBERS (*various sections*)

Cranes or other heavy erection equipment may be operated on the precast *concrete* or precast, prestressed *concrete* structural members only if approved in writing and if a proposed operating procedure is submitted showing loading, distribution of loads, resulting stresses, and that the design of the structural members is satisfactory to handle these loads. However, such approval shall not relieve the Contractor of any damage from this operation.

707.10 Blank

707.11 Method of Measurement

Precast *concrete* or precast, prestressed concrete structural members will be measured by the linear foot. Railing will be measured in accordance with 706.07 if specified as a pay item. Structural steel for intermediate diaphragms will not be measured.

707.12 Basis of Payment

The accepted quantities of precast *concrete* or precast, prestressed concrete structural members will be paid for at the contract unit price per linear foot for structural member, concrete, of the type and size specified.

SECTION 707, BEGIN LINE 506, DELETE AND INSERT AS FOLLOWS:

No payment will be made for removing and replacing prestressing strands due to excessive wire breakage, or replacing precast *concrete* or precast, prestressed *concrete* structural members damaged during handling, storing, transporting or erecting.

COMMENTS AND ACTION

DIVISION 700 – STRUCTURES (*various sections*)

DISCUSSION:

This item was introduced and presented by Mr. Reilman who stated that inconsistent terminology and punctuation in 707 is creating confusion.

Mr. Reilman proposed to clean up 707, since it is describing two products: precast concrete structural members and precast prestressed concrete structural members. This proposal standardizes the terminology and clears up confusion by removing a comma inserted between precast and prestressed (...precast, prestressed...) beginning with the 2022 spec book.

And addition to 707.04(c) was added, and Mr. Reilman revised his motion.

There was no further discussion and this item passed as revised.

	<u>Action:</u>
Motion: Mr. Reilman	— Passed as Submitted
Second: Mr. White	<u>X</u> Passed as Revised
Ayes: 10	— Withdrawn
Nays: 0	
FHWA Approval: Yes	
2022 Standard Specifications Sections referenced and/or affected: 707 begin pg 663 thru 674.	<u>X</u> 2024 Standard Specifications Revise Pay Items List
Recurring Special Provisions or Plan Details: 707-B-318 PRECAST AND PRECAST PRESTRESSED CONCRETE STRUCTURAL MEMBERS	— Create RSP (No. __) Effective:
Standard Drawing affected: NONE	— Revise RSP (No. __) Effective:
Design Manual Sections affected: NONE	— Standard Drawing Effective:
GIFE Sections cross-references: NONE	— Create RPD (No. __) Effective:
	— GIFE Update
	— Frequency Manual Update
	— SiteManager Update

PROPOSAL TO STANDARDS COMMITTEE

PROBLEMS(S) ENCOUNTERED:

- Construction method for geotextile placement needed.
- Geosynthetics types called out in this section are not matching with the proposed 918 (Geosynthetic Materials) specification.
- It is hard to compact the aggregates in 3 inch thickness.

PROPOSED SOLUTION:

- Add detailed placement method of geotextile for pavement, subgrade or embankment added.
- Revise Geosynthetics types in accordance with the proposed 918 specification.
- Revise GCS (Geocell Confinement System) to improve compaction and construction.

APPLICABLE STANDARD SPECIFICATIONS: 214

APPLICABLE STANDARD DRAWINGS: NA

APPLICABLE DESIGN MANUAL SECTION: NA

APPLICABLE SECTION OF GIFE: NA

APPLICABLE RECURRING SPECIAL PROVISIONS: 214-R-733

PAY ITEMS AFFECTED: No

APPLICABLE SUB-COMMITTEE ENDORSEMENT: ICA, Subcontractors, Area Engineers, Material Engineers and Geotechnical Engineers.

IMPACT ANALYSIS (attach report): NA

Submitted by: Jim Reilman for Nayyar Siddiki

Title: State Materials Engineer

Organization: INDOT

Phone Number: 317-522 9692

Date: 10/24/2022

IMPACT ANALYSIS REPORT CHECKLIST

Explain the business case as to why this item should be presented to the Standards Committee for approval. Answer the following questions with Yes, No or N/A.

Does this item appear in any other specification sections? No

Will approval of this item affect the Approved Materials List? No

Will this proposal improve:

Construction costs: NA
Construction time: NA
Customer satisfaction? NA
Congestion/travel time? NA
Ride quality? NA

Will this proposal reduce operational costs or maintenance effort? NA

Will this item improve safety:

For motorists? NA
For construction workers? NA

Will this proposal reduce operational costs or maintenance effort? NA

Will this item improve safety:

For motorists? NA
For construction workers? NA

Will this proposal improve quality for:

Construction procedures/processes? Yes
Asset preservation? NA
Design process? NA

Will this change provide the contractor more flexibility? NA

Will this proposal provide clarification for the Contractor and field personnel? NA

Can this item improve/reduce the number of potential change orders? NA

Is this proposal needed for compliance with:

Federal or State regulations: No
AASHTO or other design code: No

Is this item editorial? No

Provide any further information as to why this proposal should be placed on the Standards Committee meeting Agenda: _____

REVISION TO 2022 SPECIAL PROVISIONS

214-R-733 GEOSYNTHETICS

214-R-733 GEOSYNTHETICS

(Revised 09-16-21)

The Standard Specifications are revised as follows:

SECTION 214, BEGIN LINE 1, DELETE AND INSERT AS FOLLOWS:

SECTION 214 – GEOSYNTHETICS

214.01 Description

This work shall consist of furnishing and installing geosynthetics as shown on the plans or as directed by the Engineer and in accordance with 105.03.

MATERIALS

214.02 Materials

Materials shall be in accordance with the following:

Coarse Aggregate	904.03*
Geocell Confinement System.....	918.04
Geogrid.....	918.05
Geotextile for Pavement and Subgrade.....	918.02

~~Notes: Coarse Aggregate*Only No. 2, 5, 43, 53, or 73, shall be used only. ACBF Slag shall not be allowed.~~

CONSTRUCTION REQUIREMENTS

214.03 Foundation Preparation

The embankment foundation shall be cleared and grubbed in accordance with 201 and excavated using lightweight equipment to minimize disturbance of the embankment foundation surface soils. Construction activities using equipment which cause pumping and rutting of the embankment foundation soils shall be prevented where possible and shall otherwise be minimized. Fine grading may be waived where impractical. When very soft soil is encountered, the embankment foundation shall be cleared of all trash and rubbish materials without disturbing the vegetation cover or root mat. The embankment foundation shall be subject to approval prior to placement of geosynthetics. Proofrolling of the embankment foundation will not be required in accordance with 203.09 when geosynthetics are used in construction of embankment foundation treatment.

(a) Geotextile as a Drainage Blanket

Geotextile shall be stored in such a manner as to prevent exposure to direct sunlight and damage by other construction activities. Geotextile shall be placed taut and transversely after backfilling all wheel tracks. Geotextile shall be overlapped by 3 ft and sewn in accordance with the manufacturer’s guidelines.

REVISION TO 2022 SPECIAL PROVISIONS

214-R-733 GEOSYNTHETICS

Coarse aggregate No. 2 or No. 5 shall be placed as directed and encapsulated with geotextile. Coarse aggregate shall be placed by spreading dumped material over previously placed material with light equipment in such a manner as to prevent damage to the geotextile. Dumping of coarse aggregate will be allowed on *the* initial working platform. The overlap shall be staggered throughout the roadway profile. Coarse aggregate shall be placed to the full required thickness and compacted before any loaded trucks are allowed on the blanket. The drainage blanket shall have positive drainage.

No vehicles or construction equipment ~~shall~~ *will* be allowed on the geotextile prior to placement of the coarse aggregate. Damaged geotextile shall be repaired or replaced as directed. Damaged geotextile may be patched by placing a piece of the same geotextile over the damaged area. The overlap shall be at least 3 ft wide. The remaining lifts of the embankment shall be in accordance with 203.23.

(b) Geotextile Placement for Pavement, Subgrade, or Embankment

The subgrade or embankment shall be proofrolled in accordance with 203.26 and any defect or rut shall be repaired as directed prior to the geotextile placement. Geotextile shall be placed taut, without wrinkles and stretched in tension. Coarse aggregate shall be placed with a minimum disturbance to grade. Any damage to geotextile shall be repaired in accordance with 214.03(a). The remaining grade shall be constructed in accordance with 207. *Geotextile for pavement, subgrade, or embankment shall be in accordance with 918.02(c).*

When geotextile for moisture management is specified, the grade shall be prepared in such a way as to provide positive drainage. The surface shall be prepared in accordance with 201.03 and compacted in accordance with 203.23. All rocks shall be broken and compacted in accordance with 203.24. Geotextiles shall be placed taut, without wrinkles, in accordance with the manufacturer's guidelines, as shown on the plans, or as specified. Damaged geotextile shall be replaced. Geotextile for moisture management shall be in accordance with 918.02(d).

Geotextile shall be covered within three calendar days of placement.

(c) Geogrid Placement in ~~Embankment and Subgrade~~

The geogrid shall be installed in accordance with the Engineer's designs or the manufacturer's recommendations. The geogrid shall be kept taut during placement of the initial lift of backfill. Installation shall require the use of stakes, staples, sandbags, pile of granular fill, or other approved means to hold the geogrid in place during fill placement operations. ~~Type IA geogrid shall be used for embankment foundation treatment. Type IB geogrid shall be used for subgrade treatment, type IV.~~ When placing *the type IA geogrid in the embankment foundation, any* rutting in the granular material shall not exceed 3 in. ~~in the embankment foundation.~~ The Engineer may increase the lift thickness to obtain stability of the granular material.

~~If required by the Engineer, the geogrid material supplier shall provide a qualified manufacturer's representative on the contract site at the start of the work to assist the~~

REVISION TO 2022 SPECIAL PROVISIONS

214-R-733 GEOSYNTHETICS

~~Contractor. The representative shall also be available during the construction when required by the Engineer or the Contractor.~~

~~When type IB the geogrid is used~~*specified for subgrade*, proofrolling shall be performed in accordance with 203.26 prior to placing the ~~type IB~~ geogrid. Deflection or rutting shall not exceed 1 in. Any defect shall be repaired as directed. The first 6 in. of coarse aggregate No. 53 shall be spread and compacted with a 10 t roller in static mode. ~~The s~~Spreading and compaction of the aggregate shall be performed so that ~~adequate interlocking of the aggregate and geogrid is obtained~~*interlock*. The second 6 in. of coarse aggregate No. 53 shall be constructed in accordance with 301.

When geogrid is specified for subbase or base applications, geogrid shall be placed as shown on the plans and in accordance with the manufacturer's guidelines.

When specified, the geogrid material supplier shall provide a qualified manufacturer's representative on site at the start of the work to assist the Contractor. The representative shall also be available during the construction when requested by the Engineer or the Contractor.

The geogrid shall be overlapped a minimum of 2 ft side to side and end to end for *subgrade, subbase, and base applications* ~~type IB~~. The ~~type IA~~ gGeogrids shall be overlapped 3 ft in areas where foundation conditions cannot support foot traffic or where 2 ft is found to be inadequate during fill placement. Overlaps shall be oriented in the direction of fill placement, or shingled, to prevent advancing fill from lifting any geogrid roll edges. Overlaps shall be further secured to prevent separation during fill placement. Damaged geogrid shall be patched. Patching shall include placement of a minimum of 3 ft of overlapped geogrid beyond the damaged area. If the damaged portion extends for more than 50% of the roll in the width direction, the entire width shall be replaced.

Geogrid shall be covered with fill within three calendar days after placement. Only that amount of geogrid required for pending work shall be placed to minimize exposure of the geogrid.

(d) Geocell Confinement System

The Contractor shall construct the grade in accordance with 203. A layer of geotextile shall be placed in accordance with 214.03(b) and shall be anchored at the roadway edge when widening or when intersecting an existing roadway. The geocell confinement system, GCS, shall be placed and anchored as shown on the plans, or as directed. *The GCS shall be oriented with the smaller cell dimension perpendicular to the roadway.* The Contractor shall ensure that the GCS is anchored vertically and the geocell shall be filled with a minimum of ~~34 in.~~ *of coarse aggregate No. 5, No. 8, or No. 43* *No. 53 or No. 73. If the Contractor chooses No. 5 or No. 8, geotextile in accordance with 918.02(a), Type 1B shall be placed on the GCS before placing No. 53 or No. 73. The GCS shall be oriented with the smaller cell dimension perpendicular to the roadway. The remaining GCS shall be filled with No. 53 or No. 73 and at least* *On top of the GCS, 98 in.* of No. 53 or No. 73 shall be placed ~~on the GCS~~ *for a total aggregate thickness of 12 in.* The

REVISION TO 2022 SPECIAL PROVISIONS

214-R-733 GEOSYNTHETICS

aggregate shall be back dumped and compacted with a light roller in accordance with 301. No trucks or construction vehicles ~~shall~~ will be allowed on the GCS. A light tracked bulldozer or other equipment may be used as directed. ~~A~~The 6 in. lift above GCS shall be compacted with low frequency and amplitude, with a minimum of six passes. The remaining aggregate shall be placed and compacted lightly ~~at first, then with high amplitude~~. Efforts shall be made to ensure that the geotextile and GCS are in tension. ~~The Contractor may propose an alternate means of providing a typical section for the GCS, and shall submit the proposal to the Engineer for review and approval. The proposal shall be certified by a professional engineer licensed in the State of Indiana.~~

The Contractor may propose an alternate means of providing a typical section for the GCS, and shall submit the proposal to the Engineer for review and approval. The proposal shall be certified by a professional engineer registered in the State of Indiana.

GCS shall be constructed in accordance with 207 and 214.

214.04 Fill Placement

Construction vehicles ~~shall~~ will not be *allowed* on the ~~geogrid~~ geosynthetic. The placement of the fill shall proceed forward along the roadway centerline and outward to the embankment edges and compacted in accordance with 203.23. The Engineer may waive density requirements for the first lift of embankment foundation treatment if the fill is determined to be too weak to support compaction equipment.

214.05 Method of Measurement

Geotextile for pavement, ~~and~~ subgrade, *embankment, and moisture management* will be measured by the square yard, for the type specified. Geotextile for coarse aggregate and drainage blankets will be measured in accordance with 301 and 616, respectively. Geogrid will be measured by the square yard, for the type specified. The quantity will be computed based on the total area of geosynthetics shown on the plans. The aggregate used for the embankment foundation improvement will be measured in accordance with 301.09. The geogrid reinforced subgrade, *GCS, and the excavation required to place the GCS* will be measured in accordance with 207.05.

~~The GCS and the excavation required to place the GCS will not be measured.~~

214.06 Basis of Payment

The accepted quantity of geotextile will be paid for at the contract unit price per square yard per type of geotextile. *Geotextile for subgrade and geotextile for embankment will be paid for as geotextile for pavement, for the type specified, at the contract unit price per square yard.* The accepted quantities of geogrid will be paid for at the contract unit price per square yard per type of geogrid. The aggregates will be paid for in accordance with 301.10. The geogrid reinforced subgrade will be paid for in accordance with 207.06.

Payment will be made under:

COMMENTS AND ACTION

214-R-733 GEOSYNTHETICS

DISCUSSION:

Mr. Reilman introduced and presented this item explain that in section 214, the construction method for geotextile placement needed. Also, Geosynthetics types called out in 214 are not matching with the proposed 918 (Geosynthetic Materials) specification. Mr. Reilman further stated that it is hard to compact the aggregates in 3 inch thickness. Further explanations and clarification were provided by Mr. Siddiki.

Mr. Reilman proposed to add a detailed placement method of geotextile for pavement, subgrade or embankment. Mr. Reilman also proposed to revise Geosynthetics types in accordance with the proposed 918 specification, and to revise GCS (Geocell Confinement System) to improve compaction and construction.

There was no further discussion and this item passed as submitted.

<p>Motion: Mr. Reilman Second: Mr. Dave Ayes: 10 Nays: 0 FHWA Approval: Yes</p>	<p><u>Action:</u> <input checked="" type="checkbox"/> Passed as Submitted <input type="checkbox"/> Passed as Revised <input type="checkbox"/> Withdrawn</p>
<p>2022 Standard Specifications Sections referenced and/or affected: 214 begin pg 241.</p> <p>Recurring Special Provisions or Plan Details: 214-R-733 GEOSYNTHETICS</p> <p>Standard Drawing affected: NONE</p> <p>Design Manual Sections affected: NONE</p> <p>GIFE Sections cross-references: NONE</p>	<p><input checked="" type="checkbox"/> 2024 Standard Specifications Revise Pay Items List</p> <p><input type="checkbox"/> Create RSP (No. __) Effective:</p> <p><input checked="" type="checkbox"/> Revise RSP (No. 214-R-733) Effective: June 1, 2023</p> <p><input type="checkbox"/> Standard Drawing Effective:</p> <p><input type="checkbox"/> Create RPD (No. __) Effective:</p> <p><input type="checkbox"/> GIFE Update <input type="checkbox"/> Frequency Manual Update <input type="checkbox"/> SiteManager Update</p>

PROPOSAL TO STANDARDS COMMITTEE

PROBLEMS(S) ENCOUNTERED:

- Geosynthetics except geotextile are not approved through NTPEP.
- Some geosynthetics types are not used.
- Requirements of geotextile for moisture management are needed.

PROPOSED SOLUTION:

- Approval requirements for geotextile and other geosynthetics are revised and added.
- Remove the type of geosynthetics that are not used.
- Add a table for Requirements of geotextile for moisture management.

APPLICABLE STANDARD SPECIFICATIONS: 918

APPLICABLE STANDARD DRAWINGS: NA

APPLICABLE DESIGN MANUAL SECTION: NA

APPLICABLE SECTION OF GIFE: NA

APPLICABLE RECURRING SPECIAL PROVISIONS: 918-M-060

PAY ITEMS AFFECTED: No

APPLICABLE SUB-COMMITTEE ENDORSEMENT: ICA, Subcontractors, Area Engineers, Material Engineers and Geotechnical Engineers.

IMPACT ANALYSIS (attach report):

Submitted by: Jim Reilman for Nayyar Siddiki

Title: State Materials Engineer

Organization: INDOT

Phone Number: 317-522 9692

Date: 10/24/2022

IMPACT ANALYSIS REPORT CHECKLIST

Explain the business case as to why this item should be presented to the Standards Committee for approval. Answer the following questions with Yes, No or N/A.

Does this item appear in any other specification sections? No

Will approval of this item affect the Approved Materials List? No

Will this proposal improve:

Construction costs: NA
Construction time: NA
Customer satisfaction? NA
Congestion/travel time? NA
Ride quality? NA

Will this proposal reduce operational costs or maintenance effort? NA

Will this item improve safety:

For motorists? NA
For construction workers? NA

Will this proposal reduce operational costs or maintenance effort? NA

Will this item improve safety:

For motorists? NA
For construction workers? NA

Will this proposal improve quality for:

Construction procedures/processes? Yes
Asset preservation? NA
Design process? NA

Will this change provide the contractor more flexibility? NA

Will this proposal provide clarification for the Contractor and field personnel? NA

Can this item improve/reduce the number of potential change orders? NA

Is this proposal needed for compliance with:

Federal or State regulations: No
AASHTO or other design code: No

Is this item editorial? No

Provide any further information as to why this proposal should be placed on the Standards Committee meeting Agenda:

REVISION TO 2022 SPECIAL PROVISIONS

918-M-060 GEOSYNTHETIC MATERIALS

918-M-060 GEOSYNTHETIC MATERIALS

(Adopted 05-20-21)

The Standard Specifications are revised as follows:

SECTION 918, BEGIN LINE 3, DELETE AND INSERT AS FOLLOWS:

918.01 General Requirements

Geosynthetics are polymer-based products used for separation, filtration, reinforcement, liquid containment, *moisture management*, soil and aggregate confinement, and many other soil related purposes within many conventional civil engineering structures. When appropriate, the Department will require the use of geosynthetics meeting the categories and characteristics indicated below.

~~A manufacturer requesting that a geosynthetic be added to the QPL shall submit the required documents in accordance with ITM 806 to the Department's Division of Materials and Tests. Geosynthetic materials including geotextile, geomembrane, geocell, and geogrid shall be selected from the QPL of Geosynthetic Materials. Geosynthetics will be considered for inclusion on the QPL in accordance with ITM 806 Procedure S. The product shall be labeled clearly and indicate the manufacturer or private labeler name, product identification, lot number, manufactured date, and roll dimensions.~~

Geosynthetics shall be protected from temperatures greater than 140°F, mud, dirt, dust, and debris during shipment and storage. Manufacturer recommendations shall be followed with regard to protection from direct sunlight. Geosynthetics shall be identified, stored, and handled in accordance with ASTM D4873. Damaged geosynthetics shall be replaced for the entire width of the roll.

918.02 Geotextile

The geotextile shall be either non-woven or woven and consist of at least 85% long-chain synthetic polymers. The geotextile shall contain stabilizers or inhibitors added to the base polymer mix to make the filaments and yarns resistant to deterioration caused by ultraviolet radiation exposure. The geotextile shall be produced such that the yarns and fibers retain their relative positions. The non-woven geotextile shall be needle punched, heat bonded, or resin bonded.

~~All damaged geotextile shall be replaced for the entire width of the roll. The Contractor shall furnish the product labeled that clearly indicates the manufacturer's or supplier's name, product identification, lot number, manufactured date, and roll dimensions. Geotextiles used for Department projects shall be NTPEP listed and shall be in accordance with AASHTO M 288 and the QPL of Geosynthetic Materials. Geotextiles will be placed and maintained on the QPL in accordance with ITM 806.~~

The geotextile shall meet the following requirements:

REVISION TO 2022 SPECIAL PROVISIONS

918-M-060 GEOSYNTHETIC MATERIALS

(a) Geotextile Properties for Riprap and Revetment Applications

Test	Method, ASTM	Requirements ⁽¹⁾				
		Type 1A	Type 1B	Type 2A	Type 2B	Type 3
Grab Tensile Strength, min.	D4632	200 lb	200 lb	250 lb	300 lb	250 lb
Grab Elongation	D4632	> 50%	< 50%	> 50%	< 50%	< 50%
CBR Puncture Strength, min.	D6241	500 lb	600 lb	625 lb	1,000 lb	875 lb
Trapezoid Tearing Strength, min.	D4533	80 lb	75 lb	100 lb	150 lb	60 lb
Deterioration in Tensile Strength due to UV Degradation 500 hrs, min.	D4355 D6637	70% strength retained	70% strength retained	70% strength retained	70% strength retained	90% strength retained
Apparent Opening Size, AOS	D4751	≤ No. 80 sieve, for soils ≥ 40% passing the No. 200 sieve	≤ No. 40 sieve, for soils < 40% passing the No. 200 sieve	≤ No. 100 sieve, for soils ≥ 40% passing the No. 200 sieve	≤ No. 40 sieve, for soils < 40% passing the No. 200 sieve	≤ No. 70 sieve
Permittivity	D4491	≥ 1.2 sec ⁻¹	≥ 2.1 sec⁻¹	≥ 0.80 sec ⁻¹	≥ 0.90 sec ⁻¹	0.28 sec⁻¹
Note: ⁽¹⁾ All values are minimum average roll values (MARV) as determined in accordance with ASTM D4354 in the weaker principal direction, except AOS size is based on maximum average roll value.						

(b) Geotextile Properties for Underdrains, *Subsurface Drains*, and *Drainage Filtration* Applications

Test	Method, ASTM	Requirements ⁽¹⁾⁽²⁾				
		Type 1A	Type 1B	Type 2A	Type 2B	Type 3
Grab Tensile Strength, min.	D4632	80 lb	200 lb	160 lb	200 lb	200 lb
Grab Elongation	D4632	> 50%	< 50%	> 50%	< 50%	< 50%
CBR Puncture Strength, min.	D6241	175 lb	600 lb	410 lb	750 lb	1,100 lb
Deterioration in Tensile Strength due to UV Degradation 500 hrs, min.	D4355 D6637	70% strength retained	70% strength retained	70% strength retained	70% strength retained	90% strength retained
Apparent Opening Size,	D4751	≤ No. 50	≤ No. 40 sieve,	≤ No. 70 sieve,	≤ No. 30 sieve,	≤ No. 40

REVISION TO 2022 SPECIAL PROVISIONS

918-M-060 GEOSYNTHETIC MATERIALS

AOS		sieve, for soils \geq 40% passing the No. 200 sieve	for soils $<$ 40% passing the No. 200 sieve	for soils \geq 40% passing the No. 200 sieve	for soils $<$ 40% passing the No. 200 sieve	sieve
Permittivity	D4491	$\geq 1.2 \text{ sec}^{-1}$	$\geq 2.1 \text{ sec}^{-1}$	$\geq 0.8 \text{ sec}^{-1}$	$\geq 0.9 \text{ sec}^{-1}$	0.90 sec^{-1}
Notes:						
(1) All values are minimum average roll values (MARV) as determined in accordance with ASTM D4354 in the weaker principal direction, except AOS size is based on maximum average roll value.						
(2) Type 3 value is a maximum average roll value (Max ARV) as determined in accordance with ASTM D4354.						

(c) Geotextile Properties for Pavement or Subgrade Stabilizations

Test	Method, ASTM	Requirements ⁽¹⁾			
		Type 1A	Type 1B	Type 2A	Type 2B
Grab Tensile Strength, min.	D4632	200 lb	300 lb	290 lb	400 lb
Wide Width Tensile , @ 5% Strain, min.	D4595	n/a	n/a	1,200 lb/ft	2,400 lb/ft
Grab Elongation	D4632	$\leq 50\%$	$< 50\%$	$\leq 50\%$	$< 50\%$
CBR Puncture Strength, min.	D6241	175 lb	600 lb	410 lb	750 lb
Trapezoid Tearing Strength, min.	D4533	75 lb	110 lb	n/a	n/a
Deterioration in Tensile Strength due to UV Degradation 500 hrs, min.	D4355 D6637	70% strength retained	70% strength retained	70% strength retained	70% strength retained
Apparent Opening Size, AOS, min.	D4751	No. 50 sieve	No. 40 sieve	No. 30 sieve	No. 30 sieve
Soil Retention, Pore Size, O_{50}/O_{95} , min.	D6767	n/a	n/a	290/380	100/350
Permittivity, min.	D4491	0.05 sec^{-1}	0.050 sec^{-1}	0.50 sec^{-1}	0.40 sec^{-1}
Note:					
(1) All values are minimum average roll values (MARV) as determined in accordance with ASTM D4354 in the weaker principal direction, except AOS size is based on maximum average roll value.					

(d) Geotextile Properties for Moisture Management

Type 7 IMA geotextile shall consist of woven polypropylene filaments, wicking filaments and shall be in accordance with the following:

Test	Method, ASTM	Requirements
		Type IMA
Wide Width Tensile Strength, min. Machine direction Cross machine direction	D4595 ³	5,280 lbs/ft 5,280 lbs/ft
Wide Width Tensile Strength, @ 2% Strain, min. Machine direction Cross machine direction	D4595 ³	480 lbs/ft 1,080 lbs/ft
Apparent Opening Size, AOS, min.	D4751	No. 40 sieve
Flow Rate	D4491 ³	30 gal./min/ft ²
Wicking Requirement Wet Front Movement ¹ 24 minutes, min.	C1559 ²	6 in. Vertical Direction
Wicking Requirement	C1559 ²	73 in. Horizontal Direction

REVISION TO 2022 SPECIAL PROVISIONS

918-M-060 GEOSYNTHETIC MATERIALS

<i>Wet Front Movement¹ 983 minutes. Zero Gradient, min.</i>		
<i>Permittivity, min.</i>	<i>D4491³</i>	<i>0.4 sec⁻¹</i>
<i>Notes:</i>		
<i>1. 'STP': Standard Temperature and Pressure</i>		
<i>2. Modified, time</i>		
<i>3. Minimum average roll values shall be in accordance with ASTM D4759</i>		

(de) Geotextile Properties for Silt Fence

Test	Method, ASTM	Requirements ⁽¹⁾	
		Wire Fence Supported	Self Supported
Grab Strength	D4632	90 lb	90 lb
Elongation @ 45 lb	D4632		50% max.
Apparent Opening Size ⁽²⁾	D4751	No. 20 sieve	No. 20 sieve
Permittivity ⁽²⁾	D4491	0.01 sec ⁻¹	0.01 sec ⁻¹
Ultraviolet Degradation at 500 hrs	D4355	70% strength retained	70% strength retained
⁽¹⁾ The value in the weaker principal direction shall be used. All numerical values will represent the minimum average roll value. Test results from a sampled roll in a lot shall be in accordance with or shall exceed the minimum values shown in the above table. The stated values are for non-critical, non-severe conditions. Lots shall be sampled in accordance with ASTM D4354. ⁽²⁾ The values reflect the minimum criteria currently used. Performance tests may be used to evaluate silt fence performance if deemed necessary by the Engineer. Note: All values are minimum average roll values (MARV) as determined in accordance with ASTM D4354.			

918.03 Geomembrane

This material shall consist of a geomembrane fabricated from high density polyethylene, HDPE, consisting of strong, rot resistant, chemically stable long-chain synthetic polymer materials, dimensionally stable with distinct and measurable openings. The ~~manufactures~~ manufacturer shall submit the tests for the intended use to the ~~Department~~ Geotechnical Engineering Division.

~~Geomembrane shall be selected from the QPL of Geosynthetic Materials. Geomembrane will be placed and maintained on the QPL in accordance with ITM 806.~~

SECTION 918, BEGIN LINE 60, INSERT AS FOLLOWS:

918.04 Geocell Confinement System

Geocell confinement system is a lightweight, flexible mat that consists of high density polyethylene strips. The mat shall be perforated, and the strips shall be ultrasonic bonded together to form a strong configuration. Cell seam strength shall be uniform over full depth. *Geocell materials shall be 4 in. in depth.*

~~Geocell shall be selected from the QPL of Geosynthetic Materials. Geocell will be placed and maintained on the QPL in accordance with ITM 806.~~

REVISION TO 2022 SPECIAL PROVISIONS

918-M-060 GEOSYNTHETIC MATERIALS

SECTION 918, BEGIN LINE 72, INSERT AS FOLLOWS:

918.05 Geogrid

Geogrid shall be a biaxial or multi axial of a regular network of connected polymer tensile elements with aperture geometry sufficient to enable significant mechanical interlock with the surrounding material. The material shall be polypropylene, ASTM D4101 (97% minimum) and Carbon Black, ASTM D1603 (0.5% minimum). The geogrid structure shall be dimensionally stable and shall be able to retain its geometry under construction stresses. The geogrid structure shall have a resistance to damage during construction, ultraviolet degradation, and all forms of chemical and biological degradation encountered in the soil being placed.

Geogrid shall be in accordance with the property requirements as specified in the Geosynthetic Research Institute, GRI, Standard Test Methods GG1, GG3, GG4, ASTM D5262, and ASTM D6637.

~~During periods of shipment and storage, the geogrid shall be protected from temperatures greater than 140°F, mud, dirt, dust, and debris. Each geogrid roll shall be labeled or tagged to provide product identification. The manufacturer's recommendations shall be followed with regard to protection from direct sunlight. At the time of installation, the geogrid will be rejected if it has defects, tears, punctures, flaws, deterioration, or damage incurred during manufacture, transportation, or storage. All damaged portions of geogrid shall be replaced for the entire width of the roll. All of the geogrid shall be identified, stored, and handled in accordance with ASTM D4873. The Contractor shall furnish the product labels that clearly show the manufacturer's or supplier's name, product identification, lot number, manufactured date, roll dimension, and provide a document that the material is in accordance with manufacturer's or supplier's certificate.~~

~~Only geogrids selected from the QPL of Geosynthetic Materials shall be used. Geogrids will be placed and maintained on the QPL in accordance with ITM 806, Procedure S.~~

COMMENTS AND ACTION

918-M-060 GEOSYNTHETIC MATERIALS

DISCUSSION:

Mr. Reilman introduced and presented this item stating that Geosynthetics, except geotextile, are not approved through NTPEP. Some geosynthetics types are not used, and requirements of geotextile for moisture management are needed.

Mr. Reilman proposed to incorporate approval requirements for geotextile and other geosynthetics as revised and added, as shown above. Mr. Reilman proposed to remove the type of geosynthetics that are not used, and add a table for Requirements of geotextile for moisture management.

There was no further discussion and this item passed as submitted.

<p>Motion: Mr. Reilman Second: Mr. Koch Ayes: 10 Nays: 0 FHWA Approval: Yes</p>	<p><u>Action:</u></p> <p><input checked="" type="checkbox"/> Passed as Submitted <input type="checkbox"/> Passed as Revised <input type="checkbox"/> Withdrawn</p>
<p>2022 Standard Specifications Sections referenced and/or affected: 918 begin pg 1127.</p> <p>Recurring Special Provisions or Plan Details: 918-M-060 GEOSYNTHETIC MATERIALS</p> <p>Standard Drawing affected: NONE</p> <p>Design Manual Sections affected: NONE</p> <p>GIFE Sections cross-references: NONE</p>	<p><input checked="" type="checkbox"/> 2024 Standard Specifications Revise Pay Items List</p> <p><input type="checkbox"/> Create RSP (No. __) Effective:</p> <p><input checked="" type="checkbox"/> Revise RSP (No. 918-M-060) Effective: June 1, 2023</p> <p><input type="checkbox"/> Standard Drawing Effective:</p> <p><input type="checkbox"/> Create RPD (No. __) Effective:</p> <p><input type="checkbox"/> GIFE Update <input checked="" type="checkbox"/> Frequency Manual Update <input checked="" type="checkbox"/> SiteManager Update</p>

PROPOSAL TO STANDARDS COMMITTEE

PROBLEM(S) ENCOUNTERED: Desire to increase the spec range of material passing the No. 200 sieve for coarse aggregate No. 53.

PROPOSED SOLUTION: Increase the allowable top end of material passing the No. 200 sieve from 10% to 13% for coarse aggregate No. 53

APPLICABLE STANDARD SPECIFICATIONS: 904.03

APPLICABLE STANDARD DRAWINGS: None

APPLICABLE DESIGN MANUAL SECTION: None

APPLICABLE SECTION OF GIFE: None

APPLICABLE RECURRING SPECIAL PROVISIONS: 904-M-059

PAY ITEMS AFFECTED: None

APPLICABLE SUB-COMMITTEE ENDORSEMENT: Ad hoc: Matt Beeson, Melissa Ehrhart, Jim Reilman, Bart Williamson

IF APPROVED AS RECURRING SPECIAL PROVISION OR PLAN DETAILS, PROPOSED BASIS FOR USE: same BFU as existing 904-M-059 RSP

IMPACT ANALYSIS (attach report):

Submitted By: Jim Reilman

Title: State Materials Engineer

Organization: INDOT

Phone Number: (317) 522-9692

Date: 10/24/22

IMPACT ANALYSIS REPORT CHECKLIST

Explain the business case as to why this item should be presented to the Standards Committee for approval. Answer the following questions with Yes, No or N/A.

Does this item appear in any other specification sections? No

Will approval of this item affect the Approved Materials List? No

Will this proposal improve:

Construction costs? N/A

Construction time? Yes

Customer satisfaction? Yes

Congestion/travel time? N/A

Ride quality? N/A

Will this proposal reduce operational costs or maintenance effort? N/A

Will this item improve safety:

For motorists? N/A

For construction workers? N/A

Will this proposal improve quality for:

Construction procedures/processes? Yes

Asset preservation? Yes

Design process? N/A

Will this change provide the contractor more flexibility? Yes

Will this proposal provide clarification for the Contractor and field personnel? N/A

Can this item improve/reduce the number of potential change orders? N/A

Is this proposal needed for compliance with:

Federal or State regulations? No

AASHTO or other design code? No

Is this item editorial? No

Provide any further information as to why this proposal should be placed on the Standards Committee meeting Agenda:

REVISION TO SPECIAL PROVISION

904-M-059 AGGREGATES

904-M-059 AGGREGATES

(Revised 09-15-22)

The Standard Specifications are revised as follows:

SECTION 904, BEGIN LINE 152, DELETE AND INSERT AS FOLLOWS:

(f) Mineral Filler for SMA

Mineral filler shall consist of dust produced by crushing stone, portland cement, or other inert mineral matter having similar characteristics. Mineral filler shall be in accordance with the gradation requirements of 904.02(h) for size No. 16 or as approved by the Engineer. Mineral filler shall be in accordance with ITM 203 or from an ACBF slag source. The sieve analysis of mineral filler shall be conducted in accordance with AASHTO T 37 except as noted in 904.067. Mineral filler shall be non-plastic in accordance with AASHTO T 90.

SECTION 904, BEGIN LINE 276, DELETE AND INSERT AS FOLLOWS:

APPROVED MINUTES

REVISION TO SPECIAL PROVISION

904-M-059 AGGREGATES

(e) Sizes of Coarse Aggregates

Sieve Sizes	Coarse Aggregate Sizes (Percent Passing)											
	Coarse Graded										Dense Graded	
	2	5	8	9	11, SC 11 ⁽⁵⁾	12, SC 12 ⁽⁵⁾	SC 16 ⁽⁵⁾	43 ⁽¹⁾	91	93PG ⁽⁶⁾	53 ⁽¹⁾	73 ⁽¹⁾
4 in. (100 mm)												
3 1/2 in. (90 mm)												
2 1/2 in. (63 mm)	100											
2 in. (50 mm)	80 - 100											
1 1/2 in. (37.5 mm)		100						100			100	
1 in. (25 mm)	0 - 25	85 - 98	100					70 - 90	100		80 - 100	100
3/4 in. (19 mm)	0 - 10	60 - 85	75 - 95	100				50 - 70			70 - 90	90 - 100
1/2 in. (12.5 mm)	0 - 7	30 - 60	40 - 70	60 - 85	100	100	100	35 - 50		98 - 100	55 - 80	60 - 90
3/8 in. (9.5 mm)		15 - 45	20 - 50	30 - 60	75 - 95	95 - 100	94 - 100			75 - 100		
No. 4 (4.75 mm)		0 - 15	0 - 15	0 - 15	10 - 30	50 - 80	15 - 45	20 - 40		10 - 60	35 - 60	35 - 60
No. 8 (2.36 mm)		0 - 10	0 - 10	0 - 10	0 - 10	0 - 35		15 - 35		0 - 15	25 - 50	
No. 16 (1.18 mm)							0 - 4					
No. 30 (600 μm)							0 - 4	5 - 20		0 - 5	12 - 30	12 - 30
No. 200 (75 μm) ⁽²⁾								0 - 6.0			5.0 - 10 3.0 ⁽⁴⁾	5.0 - 12.0
Decant (PCC) ⁽³⁾		0 - 1.5	0 - 1.5	0 - 1.5	0 - 1.5	0 - 1.5			0 - 1.5			
Decant (Non-PCC)	0 - 2.5	0 - 2.5	0 - 3.0	0 - 2.5	0 - 2.5	0 - 2.0			0 - 2.5	0 - 2.0		
Decant (SC)					0 - 1.5	0 - 1.5	0 - 1.5					

- Notes:
- (1) The liquid limit shall not exceed 25 (35 if slag) and the plasticity index shall not exceed 5. The liquid limit shall be determined in accordance with AASHTO T 89 and the plasticity index in accordance with AASHTO T 90.
 - (2) Includes the total amount passing the No. 200 (75 μm) sieve as determined by AASHTO T 11 and AASHTO T 27.
 - (3) Decant may be 0 - 2.5 for stone and slag.
 - (4) When slag is used for separation layers as defined in 302.01, the total amount passing the No. 200 (75 μm) sieve shall be 10.0 to 12.0.
 - (5) Seal coat (SC) aggregates shall be 85% one face and 80% two face crushed. The Flakiness Index in accordance with ITM 224 shall be a maximum of 25%.
 - (6) Pea gravel shall be generally uncrushed gravel, with a maximum of 20% crushed particles, and shall meet the gradation requirements of 93PG. Determination of crushed particles shall be made from the weight (mass) of material retained on the No. 4 (4.75 mm) sieve in accordance with ASTM D5821.

REVISION TO SPECIAL PROVISION

904-M-059 AGGREGATES

(f) Sampling and Testing

Sampling and testing will be in accordance with the following AASHTO, ASTM, and ITMs.

Amount of Material finer than No. 200 (75 µm) Sieve*	AASHTO T 11
Brine Freeze and Thaw Soundness	ITM 209
Clay Lumps and Friable Particles	AASHTO T 112
Control Procedures for Classification of Aggregates.....	ITM 203
Crushed Particles.....	ASTM D5821
Dolomite Aggregates	ITM 205
Flat and Elongated Particles.....	ASTM D4791
Freeze and Thaw Beam Expansion.....	ITM 210
Lightweight Pieces in Aggregates*.....	AASHTO T 113
Los Angeles Abrasion.....	AASHTO T 96
Micro-Deval Abrasion	AASHTO T 327
Polished Resistant Aggregates	ITM 214
Sampling Aggregates*	AASHTO T 2
Sampling Stockpiled Aggregates	ITM 207
Scratch Hardness.....	ITM 206
Sieve Analysis*	AASHTO T 27
Soundness*.....	AASHTO T 103, AASHTO T 104
Specific Gravity and Absorption*.....	AASHTO T 85
Unit Weight and Voids in Aggregates	AASHTO T 19
*Except as noted in 904.06904.07	

SECTION 904, BEGIN LINE 342, INSERT AS FOLLOWS:

(f) Sizes of Riprap

Gradation Requirements					
Percent Smaller					
Size, in.	Revetment	Class 1	Class 2	Uniform A	Uniform B
30			100		
24		100	85 - 100		
18	100	85 - 100	60 - 80		
12	90 - 100	35 - 50	20 - 40		
8				100	
6	20 - 40	10 - 30	0 - 20	35 - 80	95 - 100
3	0 - 10	0 - 10	0 - 10		35 - 80
1				0 - 20	0 - 20
Depth of Riprap, min.	18 in.	24 in.	30 in.		

The maximum dimension of individual pieces shall not be greater than three times the minimum dimension *and no dimension shall exceed the maximum size listed for the respective size of riprap*. The riprap will be visually inspected for size, shape, and consistency.

REVISION TO SPECIAL PROVISION

904-M-059 AGGREGATES

SECTION 904, AFTER LINE 358, DELETE AND INSERT AS FOLLOWS:

904.06 B Borrow

The material used for special filling shall be of acceptable quality, free from large or frozen lumps, wood, or other extraneous matter and shall be known as B borrow. It shall consist of suitable sand, gravel, or crushed stone ACBF, GBF, or other approved material. The material shall contain no more than 10% passing the No. 200 (75 μ m) sieve and shall be otherwise suitably graded. The ratio of the fraction passing the No. 200 (75 μ m) sieve to the fraction retained on the No. 30 (600 μ m) sieve shall not exceed one-fifth. The use of an essentially one-size material will not be allowed unless approved. B borrow containing greater than 3% by dry weight organic material will not allowed.

Sieve analysis and organic material will be performed in accordance with AASHTO T 11 and AASHTO T 267.

904.067 Exceptions to AASHTO Standard Methods

(a) Exceptions to AASHTO T 2

Stockpile sampling shall be in accordance with ITM 207, unless otherwise approved.

COMMENTS AND ACTION

904-M-059 AGGREGATES

DISCUSSION:

This item was introduced and presented by Mr. Reilman who explained the desire to increase the spec range of material passing the No. 200 sieve for coarse aggregate No. 53.

Mr. Reilman proposed to increase the allowable top end of material passing the No. 200 sieve from 10% to 13% for coarse aggregate No. 53.

Mr. Siddiki confirmed that the data received backs up this revision.

Mr. Bazlamit asked if the change to the No. 200 sieve will have an effect on geotextiles. Mr. Siddiki said he doesn't foresee any problems with that. Further clarification was provided by Mr. Dave.

There was no further discussion and this item passed as submitted.

	<u>Action:</u>
Motion: Mr. Reilman	<input checked="" type="checkbox"/>
Second: Mr. Dave	<input type="checkbox"/>
Ayes: 10	<input type="checkbox"/>
Nays: 0	<input type="checkbox"/>
FHWA Approval: Yes	<input type="checkbox"/>
2022 Standard Specifications Sections referenced and/or affected: 904 begin pg 1004.	<input checked="" type="checkbox"/> 2024 Standard Specifications <input type="checkbox"/> Revise Pay Items List <input type="checkbox"/> Create RSP (No. __) Effective:
Recurring Special Provisions or Plan Details: 904-M-059 AGGREGATES	<input checked="" type="checkbox"/> Revise RSP (No. 904-M-059) Effective: <u>June 1, 2023</u>
Standard Drawing affected: NONE	<input type="checkbox"/> Standard Drawing Effective:
Design Manual Sections affected: NONE	<input type="checkbox"/> Create RPD (No. __) Effective:
GIFE Sections cross-references: NONE	<input type="checkbox"/> GIFE Update <input checked="" type="checkbox"/> Frequency Manual Update <input checked="" type="checkbox"/> SiteManager Update

PROPOSAL TO STANDARDS COMMITTEE

PROBLEM(S) ENCOUNTERED:

Curing-sealing materials are a class of surface-applied products that are intended to provide curing for fresh concrete, but also the added benefit of long-term sealing. The sealing aspect of these products is much less effective than other types of sealers that are applied to the concrete after it has hardened. The products are only allowed for slip-formed bridge railing and slip-formed median barriers. The products are rarely used, and contractors typically opt for the no-seal options allowed under 709.05(c) or a Non-Epoxy PCC Sealer (i.e. silane) is used after the concrete is hardened. Both options are preferred by the Department due to better long-term concrete quality.

PROPOSED SOLUTION:

Eliminate curing-sealing materials from the standard specification.

APPLICABLE STANDARD SPECIFICATIONS: 602.06, 702.03, 702.22(b), 709.08, 912.02

APPLICABLE STANDARD DRAWINGS: none

APPLICABLE DESIGN MANUAL SECTION: none

APPLICABLE SECTION OF GIFE: none

APPLICABLE RECURRING SPECIAL PROVISIONS: none

PAY ITEMS AFFECTED: none

APPLICABLE SUB-COMMITTEE ENDORSEMENT: ad hoc – Jim Reilman, Michael Nelson, Abul Mazumder

IMPACT ANALYSIS (attach report):

Submitted By: Jim Reilman

Title: State Materials Engineer

Organization: INDOT Office of Materials Management

Phone Number: 317-522-9692

Date: 10/20/22

IMPACT ANALYSIS REPORT CHECKLIST

Explain the business case as to why this item should be presented to the Standards Committee for approval. Answer the following questions with Yes, No or N/A.

Does this item appear in any other specification sections? No

Will approval of this item affect the Approved Materials List? Yes – The QPL of PCC Curing-Sealing Materials will be eliminated

Will this proposal improve:

Construction costs? N/A
Construction time? Yes
Customer satisfaction? N/A
Congestion/travel time? N/A
Ride quality? N/A

Will this proposal reduce operational costs or maintenance effort? No

Will this item improve safety:

For motorists? N/A
For construction workers? N/A

Will this proposal improve quality for:

Construction procedures/processes? N/A
Asset preservation? Yes
Design process? N/A

Will this change provide the contractor more flexibility? No

Will this proposal provide clarification for the Contractor and field personnel? No

Can this item improve/reduce the number of potential change orders? No

Is this proposal needed for compliance with:

Federal or State regulations? No
AASHTO or other design code? No

Is this item editorial? No

Provide any further information as to why this proposal should be placed on the Standards Committee meeting Agenda: N/A

REVISION TO 2022 STANDARD SPECIFICATIONS

SECTION 602 – CONCRETE BARRIER

602.06 Basis of Payment

SECTION 702 – STRUCTURAL CONCRETE

702.03 Materials

702.22 Curing Concrete

SECTION 709 – PORTLAND CEMENT CONCRETE SEALERS

709.08 Basis of Payment

SECTION 912 – CONCRETE CURING MATERIALS AND ADMIXTURES

912.02 Curing-Sealing Materials

The Standard Specifications are revised as follows:

SECTION 602, BEGIN LINE 123, DELETE AND INSERT AS FOLLOWS:

The cost of polyethylene film, surface seal, ~~or curing-sealing material for concrete barrier~~ and curing material shall be included in the cost of concrete barrier.

SECTION 702, BEGIN LINE 32, DELETE AS FOLLOWS:

~~Curing-Sealing Materials.....~~912.02

SECTION 702, BEGIN LINE 1172, DELETE AND INSERT AS FOLLOWS:

702.22 Curing Concrete

Concrete in bridge decks or the top surface of reinforced concrete slab bridges shall be cured continuously 24 h per day for a minimum of 168 h commencing immediately after the surface is able to support the protective covering without deformation. Water curing in accordance with 702.22(a) shall be initiated within 60 minutes after the finishing machine completes the final strike off of any portion of the concrete surface. Curing or other protective efforts which may include the use of evaporative retardants shall begin sooner if adverse conditions exist. Adverse conditions include, but are not limited to, high winds, extreme temperatures or low humidity. A work bridge shall be used following the finishing machine to facilitate the placement of curing materials, if necessary. Curing time for bridge decks and the top surface of reinforced concrete slab bridges are not controlled by beam tests and the cure time shall not be reduced. In addition to the minimum of 168 h cure period, curing shall continue until a flexural strength of 550 psi has been attained. Curing of patches or small full depth deck replacement areas on existing bridge decks that are to be overlaid, may be controlled by test beams in accordance with 702.24(a).

Unless otherwise specified, all other concrete shall be cured continuously 24 h per day for at least 96 h commencing immediately after the surface is able to support the protective covering without deformation. In addition to the required hours, curing shall continue until the flexural strength stated in 702.13(h) and 702.24 has been attained.

~~Membrane forming curing compound may be used in lieu of protective covering curing methods.~~ Where it has been determined that a surface treatment is to be used, the membrane forming curing compound shall not be used. Membrane forming curing compound shall not be used on bridge decks nor on reinforced concrete slab bridges.

The curing of surfaces to be waterproofed may be discontinued when waterproofing is started.

REVISION TO 2022 STANDARD SPECIFICATIONS

SECTION 602 – CONCRETE BARRIER

602.06 Basis of Payment

SECTION 702 – STRUCTURAL CONCRETE

702.03 Materials

702.22 Curing Concrete

SECTION 709 – PORTLAND CEMENT CONCRETE SEALERS

709.08 Basis of Payment

SECTION 912 – CONCRETE CURING MATERIALS AND ADMIXTURES

912.02 Curing-Sealing Materials

If further precautions are necessary to ensure strength, they shall be taken as directed.

(a) Protective Covering Curing Methods

~~1.(a) Water Curing Method~~

SECTION 702, BEGIN LINE 1223, DELETE AND INSERT AS FOLLOWS:

~~2.(b) Membrane Forming Curing Compound~~

SECTION 702, BEGIN LINE 1246, DELETE AS FOLLOWS:

~~(b) Curing Sealing Materials~~

~~Curing-sealing materials may be used in lieu of protective covering curing methods when surface seal is required. These materials may only be used on concrete surfaces that are not subjected to vehicular wear and that have been formed using the slip form method. Curing-sealing material shall not be applied to cast in place concrete.~~

~~When curing-sealing materials are used for curing concrete, surface seal will not be required.~~

~~The curing-sealing material shall be mixed in accordance with the manufacturer's instructions prior to application. The rate of application shall be as specified in the list of approved Curing-Sealing Materials. All concrete cured-sealed by this method shall receive two applications of the curing-sealing compound. The first coat shall be spray applied after the finished surface has been achieved. The second coat shall be applied while the first coat is still tacky.~~

~~The use of curing-sealing material shall be discontinued if plastic shrinkage cracks occur that cannot be corrected by decreasing the application rate. The concrete shall then be cured and surface sealed in accordance with 702.22(a)1 and 709, respectively.~~

~~The coating shall be protected against damage after application. All coatings that have been disturbed shall be given an additional coating. If the surface coating is continuously subjected to injury, immediate application of curing in accordance with 702.22(a)1 may be required. The concrete shall then be surface sealed in accordance with 709.~~

SECTION 709, BEGIN LINE 120, DELETE AS FOLLOWS:

~~If a curing-sealing material in accordance with 702.22(b) is used in lieu of sealing concrete surfaces or portions thereof, it will be paid for as surface seal.~~

REVISION TO 2022 STANDARD SPECIFICATIONS

SECTION 602 – CONCRETE BARRIER

602.06 Basis of Payment

SECTION 702 – STRUCTURAL CONCRETE

702.03 Materials

702.22 Curing Concrete

SECTION 709 – PORTLAND CEMENT CONCRETE SEALERS

709.08 Basis of Payment

SECTION 912 – CONCRETE CURING MATERIALS AND ADMIXTURES

912.02 Curing-Sealing Materials

SECTION 912, BEGIN LINE 58, DELETE AND INSERT AS FOLLOWS:

912.02 Curing-Sealing Materials*Blank*

~~Curing-sealing materials are single application curing and sealing products for portland cement concrete.~~

~~A QPL of PCC Curing-Sealing Materials will be maintained by the Department. The QPL will identify pre-qualified products, specify the manufacturer and product designation, and include application instructions.~~

~~In order to have a product added to the QPL of PCC Curing-Sealing Materials, a type A certification in accordance with 916 shall be provided for the curing-sealing materials. Such certification shall state that the product is in accordance with the requirements of NCHRP 244 Series IV Southern Climate Weathering Test, and ASTM C309, type 1.~~

- ~~(a) The certification shall be in accordance with the applicable requirements of 916, and shall include a dated test report. The test report shall substantiate full compliance with the specifications and establish when the testing was started. Test reports older than seven years on January 1 of the approval year will not be accepted.~~
- ~~(b) If irregularities are found in the results required for such certification, copies of the original data may be required prior to reconsideration of the certification.~~
- ~~(c) Tests shall be conducted by a state highway agency testing laboratory or a testing laboratory regularly inspected by CCRL. Proof of such inspection shall be furnished with the test report.~~

~~After a product has been qualified, it will be added to the QPL of PCC Curing-Sealing Materials. The product will remain on the list until test results on file are seven years old, provided that there are no changes in raw materials, formulation, or procedures for manufacture. Results more than seven years old or products in which there has been a change in raw materials, formulation, or procedures for manufacture shall be recertified in order to remain on the QPL.~~

~~A curing-sealing material that performs unsatisfactorily in the field will be removed from the QPL.~~

COMMENTS AND ACTION

- 602.06 Basis of Payment
- 702.03 Materials
- 702.22 Curing Concrete
- 709.08 Basis of Payment
- 912.02 Curing-Sealing Materials

DISCUSSION:

Mr. Reilman introduced and presented this item stating that curing-sealing materials are a class of surface-applied products that are intended to provide curing for fresh concrete, but also the added benefit of long-term sealing. The sealing aspect of these products is much less effective than other types of sealers that are applied to the concrete after it has hardened. The products are only allowed for slip-formed bridge railing and slip-formed median barriers. The products are rarely used, and contractors typically opt for the no-seal options allowed under 709.05(c) or a Non-Epoxy PCC Sealer, such as silane, which is used after the concrete is hardened. Both options are preferred by the Department due to better long-term concrete quality.

Mr. Reilman proposed to eliminate curing-sealing materials from the standard specification as shown above.

There was no further discussion and this item passed as submitted.

	<u>Action:</u>
Motion: Mr. Reilman	<input checked="" type="checkbox"/>
Second: Mr. Hauser	<input type="checkbox"/>
Ayes: 10	<input type="checkbox"/>
Nays: 0	<input type="checkbox"/>
FHWA Approval: Yes	<input type="checkbox"/>
<hr/>	
2022 Standard Specifications Sections referenced and/or affected: 602.06 pg 497; 702.03 pg 619; 702.22 pg 644; 709.08 pg 680; 912.02 pg 1089.	<input checked="" type="checkbox"/> 2024 Standard Specifications <input type="checkbox"/> Revise Pay Items List <input type="checkbox"/> Create RSP (No. __) Effective:
Recurring Special Provisions or Plan Details: 702-R-739 STRUCTURAL CONCRETE AND USE OF OPTIMIZED AGGREGATE GRADATION IN CONCRETE	<input type="checkbox"/> Revise RSP (No. __) Effective:
Standard Drawing affected: NONE	<input type="checkbox"/> Standard Drawing Effective:
Design Manual Sections affected: NONE	<input type="checkbox"/> Create RPD (No. __) Effective:
GIFE Sections cross-references: NONE	<input type="checkbox"/> GIFE Update <input type="checkbox"/> Frequency Manual Update <input type="checkbox"/> SiteManager Update

PROPOSAL TO STANDARDS COMMITTEE

PROBLEM(S) ENCOUNTERED: Various terms are used to refer to precompressed foam joints and other bridge expansion joints. Requirements for what is contained on the type B certification for Type SS and M joints is missing.

PROPOSED SOLUTION: incorporate proposed changes to standardize the terminology used for bridge expansion joints as well as other minor clean up for clarity.

APPLICABLE STANDARD SPECIFICATIONS: 503, 724, 906.07

APPLICABLE STANDARD DRAWINGS: 503-BATJ-02, 503-BATJ-03, 724-BSSJ drawing series

APPLICABLE DESIGN MANUAL SECTION:

APPLICABLE SECTION OF GIFE:

APPLICABLE RECURRING SPECIAL PROVISIONS: None

PAY ITEMS AFFECTED: None

APPLICABLE SUB-COMMITTEE ENDORSEMENT: Ad hoc: Jim Reilman, Pete White

IF APPROVED AS RECURRING SPECIAL PROVISION OR PLAN DETAILS, PROPOSED BASIS FOR USE: 2024 spec book and standard drawing series

IMPACT ANALYSIS (attach report):

Submitted By: Jim Reilman

Title: State Materials Engineer

Organization: INDOT

Phone Number: (317) 522-9692

Date:

IMPACT ANALYSIS REPORT CHECKLIST

Explain the business case as to why this item should be presented to the Standards Committee for approval. Answer the following questions with Yes, No or N/A.

Does this item appear in any other specification sections? No

Will approval of this item affect the Approved Materials List? No

Will this proposal improve:

Construction costs? N/A

Construction time? N/A

Customer satisfaction? N/A

Congestion/travel time? N/A

Ride quality? N/A

Will this proposal reduce operational costs or maintenance effort? N/A

Will this item improve safety:

For motorists? N/A

For construction workers? N/A

Will this proposal improve quality for:

Construction procedures/processes? Yes

Asset preservation? NA

Design process? Yes

Will this change provide the contractor more flexibility? N/A

Will this proposal provide clarification for the Contractor and field personnel? Yes

Can this item improve/reduce the number of potential change orders? N/A

Is this proposal needed for compliance with:

Federal or State regulations? No

AASHTO or other design code? No

Is this item editorial? No

Provide any further information as to why this proposal should be placed on the Standards Committee meeting Agenda:

REVISION TO 2022 STANDARD SPECIFICATIONS AND STANDARD DRAWINGS

SECTION 503 – PCCP JOINTS	724.02 Materials
503.02 Materials	724.03 General Requirements
503.03(e) Terminal Joints	SECTION 906 – JOINT MATERIALS
503.07 Method of Measurement	906.07 Bridge Expansion Joints
503.08 Basis of Payment	E 503-BATJ-02 Terminal Joint, Type PCCP
SECTION 724 – BRIDGE EXPANSION JOINTS	E 503-BATJ-03 Terminal Joint, Type HMA
724.01 Description	E 724-BSSJ series EXPANSION JOINT

The Standard Specifications are revised as follows:

SECTION 503, BEGIN LINE 9, INSERT AS FOLLOWS:

503.02 Materials

Materials shall be in accordance with the following:

<i>Bridge Expansion Joint Type PCF</i>	906.07(c)
Chemical Anchor System.....	901.05

SECTION 503, BEGIN LINE 125, DELETE AND INSERT AS FOLLOWS:

1. Terminal Joint, Type PCCP

Terminal joint, type PCCP, shall consist of a sleeper slab, polyethylene bond breaker, ~~pre-compressed foam~~ *type PCF bridge expansion joint*, and ~~jointed reinforced concrete pavement~~, JRCP, transition slabs. The polyethylene bond breaker shall be an approved polyethylene sheeting having a thickness of 6 mils or greater. The portion of the sleeper slab on which the polyethylene bond breaker is to be placed shall be finished to a smooth trowel finish. The ~~pre-compressed foam~~ *type PCF bridge expansion joint* shall be in accordance with 724 and as shown on the plans. The concrete and placement for JRCP transition slabs shall be in accordance with 502 and as shown on the plans. Steel reinforcement shall be epoxy coated and placed in accordance with 703. The metal chairs, spacers, clips, wire, or other mechanical means used for fastening or holding reinforcement in place shall be epoxy coated.

2. Terminal Joint, Type HMA

Terminal joint, type HMA, shall consist of a sleeper slab, concrete lug, polyethylene bond breaker, and ~~pre-compressed foam~~ *type PCF bridge expansion joint*. The polyethylene bond breaker shall be an approved polyethylene sheeting having a thickness of 6 mils or greater. The portion of the sleeper slab on which the polyethylene bond breaker is to be placed shall be finished to a smooth trowel finish. A type A construction joint shall be constructed as shown on the plans. The ~~pre-compressed foam~~ *type PCF bridge expansion joint* shall be in accordance with 724 and as shown on the plans.

The saw cut shall be sealed with hot poured joint sealant in accordance with 906.02(a)2.

SECTION 503, BEGIN LINE 289, DELETE AND INSERT AS FOLLOWS:

~~Pre-compressed foam joints will not be measured.~~

Retrofitted tie bars will be measured by the number of units installed.

~~Pre-compressed foam~~ *Type PCF bridge expansion joints, joint fillers, and joint*

REVISION TO 2022 STANDARD SPECIFICATIONS AND STANDARD DRAWINGS

SECTION 503 – PCCP JOINTS	724.02 Materials
503.02 Materials	724.03 General Requirements
503.03(e) Terminal Joints	SECTION 906 – JOINT MATERIALS
503.07 Method of Measurement	906.07 Bridge Expansion Joints
503.08 Basis of Payment	E 503-BATJ-02 Terminal Joint, Type PCCP
SECTION 724 – BRIDGE EXPANSION JOINTS	E 503-BATJ-03 Terminal Joint, Type HMA
724.01 Description	E 724-BSSJ series EXPANSION JOINT

sealants will not be measured.

SECTION 503, BEGIN LINE 329, DELETE AND INSERT AS FOLLOWS:

The cost of the sleeper slab, reinforcing bars, bond breaker, ~~pre-compressed foam~~ *type PCF bridge expansion joint*, joint sealant and all necessary incidentals shall be included in the cost of the terminal joint. When required, removal of an existing terminal joint and sleeper slab shall be included in the cost of the terminal joint.

SECTION 724, BEGIN LINE 13, DELETE AND INSERT AS FOLLOWS:

(c) Replacement of Existing Bridge Expansion Joint Seal

This work shall consist of the replacement of the ~~joint~~ seal in an existing bridge expansion joint of the type specified in accordance with 105.03.

MATERIALS

724.02 Materials

Materials shall be in accordance with the following:

Bridge Deck Patching Concrete.....	722
<i>Bridge Expansion Joint Type M</i>	906.07(b)
<i>Bridge Expansion Joint Type PCF</i>	906.07(c)
<i>Bridge Expansion Joint Type SS</i>	906.07(a)
Concrete, Class C.....	702
Expansion Joint M	906.07(b)
Expansion Joint PCF	906.07(c)
Expansion Joint SS	906.07(a)
Inorganic Zinc Primer.....	909.02(a)1
Rapid Set Patching Materials.....	901.07
Structural Steel.....	910.02

SECTION 724, BEGIN LINE 43, DELETE AND INSERT AS FOLLOWS:

(a) Bridge Expansion Joint Type SS

The joint assembly shall consist of one of the allowable alternates for this type of joint as shown on the plans. The strip seal shall be sized to accommodate a minimum of 4 in. of movement. The strip seal shall be furnished in one continuous length for the entire limits of the installed joint. ~~Field splicing of~~ *The strip seal will* ~~not be allowed~~ *field-spliced.*

(b) Bridge Expansion Joint Type M

The joint assembly shall be manufactured in accordance with the details shown on the working drawings as prepared by the manufacturer of the joint assembly. The strip seals

REVISION TO 2022 STANDARD SPECIFICATIONS AND STANDARD DRAWINGS

SECTION 503 – PCCP JOINTS	724.02 Materials
503.02 Materials	724.03 General Requirements
503.03(e) Terminal Joints	SECTION 906 – JOINT MATERIALS
503.07 Method of Measurement	906.07 Bridge Expansion Joints
503.08 Basis of Payment	E 503-BATJ-02 Terminal Joint, Type PCCP
SECTION 724 – BRIDGE EXPANSION JOINTS	E 503-BATJ-03 Terminal Joint, Type HMA
724.01 Description	E 724-BSSJ series EXPANSION JOINT

shall be furnished in one continuous length for the entire limits of the installed joint. ~~Field splicing of~~ The strip seals ~~will~~ shall not be allowed ~~field-spliced~~.

(c) Bridge Expansion Joint Type PCF

The joint seal shall be sized to accommodate the anticipated thermal movement range shown on the plans. The nominal joint size shall meet or exceed the existing joint mean opening size at 60°F as shown on the plans.

CONSTRUCTION REQUIREMENTS

724.03 General Requirements

All welding shall be in accordance with 711.32. All splice welds shall develop full strength. All welds which come in contact with the *strip* seals shall be ground smooth. All metal surfaces in direct contact with the *strip* seal shall be cleaned and properly treated in accordance with the manufacturer's recommendations *to provide a high strength bond between the strip seal and mating metal surfaces*. Lubricants and adhesives shall be used in accordance with the joint manufacturer's recommendations. All excess lubricant and adhesive shall be removed before it has set. *The strip seals shall be clean and free of foreign materials*.

SECTION 724, BEGIN LINE 85, INSERT AS FOLLOWS:

(c) Installation of Type PCF Joint

SECTION 906, BEGIN LINE 127, DELETE AND INSERT AS FOLLOWS:

906.07 Bridge Expansion Joints

Type SS and Type M joints, including anchor assemblies, shall be shop fabricated, delivered, and installed as a continuous unit for lengths up to 46 ft. Joints longer than 46 ft shall be furnished in continuous units or in appropriate shorter sections as shown on the working drawings and approved by the Engineer. Joints used in stage construction shall be furnished in sections appropriate to accommodate the work. All steel joints furnished in sections shall be spliced with welds, with ends prepared for welding in the shop. All welds shall be in accordance with 711.32.

~~Type PCF joints shall be fabricated, delivered, and installed in lengths no less than 6 ft. Sections of joint shall be field spliced using silicone sealant in accordance with the manufacturer's recommendations. Joints shall be furnished with the fewest number of splices possible, and sections less than 6 ft in length shall not be used unless required to complete the remaining length at the ends of a joint or construction phase. [moved below, no changes]~~

The profile of the joint in the roadway area shall conform to the roadway cross

REVISION TO 2022 STANDARD SPECIFICATIONS AND STANDARD DRAWINGS

SECTION 503 – PCCP JOINTS	724.02 Materials
503.02 Materials	724.03 General Requirements
503.03(e) Terminal Joints	SECTION 906 – JOINT MATERIALS
503.07 Method of Measurement	906.07 Bridge Expansion Joints
503.08 Basis of Payment	E 503-BATJ-02 Terminal Joint, Type PCCP
SECTION 724 – BRIDGE EXPANSION JOINTS	E 503-BATJ-03 Terminal Joint, Type HMA
724.01 Description	E 724-BSSJ series EXPANSION JOINT

section. Where changes in direction are required, such as at curbs or concrete rails, the sections shall be cut to the bevel required to produce the same cross section on each piece being joined. Slider plates shall be provided at curbs, walkways, and concrete rails as part of the completed joint assembly. The slider plate shall be the same material as the extrusion and shall be galvanized in accordance with ASTM A123.

~~All welds in contact with the elastomeric seals shall be ground smooth. Metal surfaces in direct contact with the elastomeric seal shall be cleaned and treated in accordance with the manufacturer's recommendations to provide a high strength bond between the elastomeric seal and mating metal surfaces. The elastomeric seals shall be clean and free of foreign materials.~~ [close duplication of paragraph in 724.03. edits made in 724.03]

All exposed structural steel surfaces, except stainless steel or polytetrafluoroethylene coated, shall be shop painted in accordance with 619.

Type PCF joints shall be fabricated, delivered, and installed in lengths no less than 6 ft. Sections of joint shall be field spliced using silicone sealant in accordance with the manufacturer's recommendations. Joints shall be furnished with the fewest number of splices possible, and sections less than 6 ft in length shall not be used unless required to complete the remaining length at the ends of a joint or construction phase. [moved from above, no changes]

(a) Type SS

This joint shall consist of preformed elastomeric strip seals and the corresponding steel locking edge rail.

Structural steel shall be in accordance with ASTM A36, ASTM A242, ASTM A588, ASTM A1011, ~~ASTM A242, or Merchant Quality~~ M 1010; or M 1020 in accordance with ASTM A575.

Sealant and grouts shall be in accordance with the manufacturer's recommendation.

The elastomeric compound used to manufacture the strip seal shall be neoprene and in accordance with ASTM D5973 ~~except that the physical requirements in Table 1 for low temperature recovery, high temperature recovery, and compression deflection properties will not apply.~~

The strip seal shall be furnished in one continuous length for the entire limits of the installed joint. ~~Field splicing of~~ The strip seals ~~will~~ shall not be ~~allowed~~ field-spliced. Miter cut, vulcanized shop splices will be required in the strip seal. The shop vulcanization of the

REVISION TO 2022 STANDARD SPECIFICATIONS AND STANDARD DRAWINGS

SECTION 503 – PCCP JOINTS	724.02 Materials
503.02 Materials	724.03 General Requirements
503.03(e) Terminal Joints	SECTION 906 – JOINT MATERIALS
503.07 Method of Measurement	906.07 Bridge Expansion Joints
503.08 Basis of Payment	E 503-BATJ-02 Terminal Joint, Type PCCP
SECTION 724 – BRIDGE EXPANSION JOINTS	E 503-BATJ-03 Terminal Joint, Type HMA
724.01 Description	E 724-BSSJ series EXPANSION JOINT

strip seal splice may be either a hot or cold process so long as the process produces a splice of equal or greater strength than the elastomer.

A type B certification in accordance with 916 shall be provided for the elastomeric strip seal. The limits of the following shall be shown on the certification.

<i>Property</i>	<i>Requirement</i>
<i>Tensile Strength</i>	<i>ASTM D412</i>
<i>Elongation at break</i>	<i>ASTM D412</i>
<i>Hardness, Type A durometer, points</i>	<i>ASTM D2240 (modified)</i>
<i>Oven Aging</i>	<i>ASTM D573</i>
<i>Tensile Strength, loss</i>	
<i>Elongation, loss</i>	
<i>Hardness, Type A durometer points change</i>	
<i>Oil Swell, IRM 903, weight change</i>	<i>ASTM D471</i>
<i>Ozone Resistance</i>	<i>ASTM D1149</i>
<i>Low Temperature Stiffening</i>	<i>ASTM D2240</i>
<i>Compression set</i>	<i>ASTM D395, Method B</i>

A type C certification in accordance with 916 shall be provided for the structural steel and polyurethane sealant.

(b) Type M

This joint shall consist of prefabricated multiple elastomeric seals, separator beams, and support bars. The structural design of the joint shall be in accordance with AASHTO LRFD Bridge Construction Specifications and shall be for the same design loading as the bridge structure at which it is to be installed, but not less than HS 20-44 truck loading and impact. The joint shall be designed to accommodate the movement shown on the plans.

The joint assembly shall be preset by the manufacturer in accordance with the approved working drawings, joint setting data and specifications. The assembly shall be properly secured for shipping and contain provision for final field adjustment at the time of installation. The manufacturer shall furnish a copy of the installation instructions prior to the placement of these joints.

Structural steel shall be in accordance with ASTM A36, ASTM A242, ASTM A588, ASTM A1011, ASTM A242, ASTM A588, or Merchant Quality M 1010, or M 1020 in accordance with ASTM A5765.

Sealant and grout shall be in accordance with the joint manufacturer's recommendation.

REVISION TO 2022 STANDARD SPECIFICATIONS AND STANDARD DRAWINGS

SECTION 503 – PCCP JOINTS	724.02 Materials
503.02 Materials	724.03 General Requirements
503.03(e) Terminal Joints	SECTION 906 – JOINT MATERIALS
503.07 Method of Measurement	906.07 Bridge Expansion Joints
503.08 Basis of Payment	E 503-BATJ-02 Terminal Joint, Type PCCP
SECTION 724 – BRIDGE EXPANSION JOINTS	E 503-BATJ-03 Terminal Joint, Type HMA
724.01 Description	E 724-BSSJ series EXPANSION JOINT

~~Elastomer~~ The elastomeric compound used to manufacture the seal shall be neoprene in accordance with ASTM D3542/5973.

A type B certification in accordance with 916 shall be provided for the elastomeric seals. The limits of the following shall be shown on the certification.

<i>Property</i>	<i>Requirement</i>
<i>Tensile Strength</i>	<i>ASTM D412</i>
<i>Elongation at break</i>	<i>ASTM D412</i>
<i>Hardness, Type A durometer, points</i>	<i>ASTM D2240 (modified)</i>
<i>Oven Aging</i>	<i>ASTM D573</i>
<i>Tensile Strength, loss</i>	
<i>Elongation, loss</i>	
<i>Hardness, Type A durometer points change</i>	
<i>Oil Swell, IRM 903, weight change</i>	<i>ASTM D471</i>
<i>Ozone Resistance</i>	<i>ASTM D1149</i>
<i>Low Temperature Stiffening</i>	<i>ASTM D2240</i>
<i>Compression set</i>	<i>ASTM D395, Method B</i>

A type C certification in accordance with 916 shall be provided for the structural steel and polyurethane sealant.

Bearings above and below the support bar shall be a nylon or urethane compound with polytetrafluorethylene riding surfaces. All components of the system shall be accessible to periodic inspection and component replacement if necessary.

The ~~elastomer~~ seals shall be in accordance with the requirements as follows:

SECTION 906, BEGIN LINE 235, INSERT AS FOLLOWS:

9. have a hollow box shape for joints utilizing urethane *or mechanical* equilibrium control spacers or a strip seal configuration for joints using a mechanical linkage to maintain equidistant separator beam spacing. The joint shall have a maximum opening of 3 in. per seal.

SECTION 906, BEGIN LINE 273, DELETE AND INSERT AS FOLLOWS:

(c) Type PCF

~~Pre-compressed foam joints, PCF,~~ This joint shall be furnished from the Department's list *QPL* of approved Type PCF Bridge Joints. ~~PCF j~~ Joints may be added to the approved list *QPL* by completing the requirements of ITM 806, Procedure C.

REVISION TO 2022 STANDARD SPECIFICATIONS AND STANDARD DRAWINGS

E 503-BATJ-02 AND -03 TERMINAL JOINT (WITH MARKUPS)

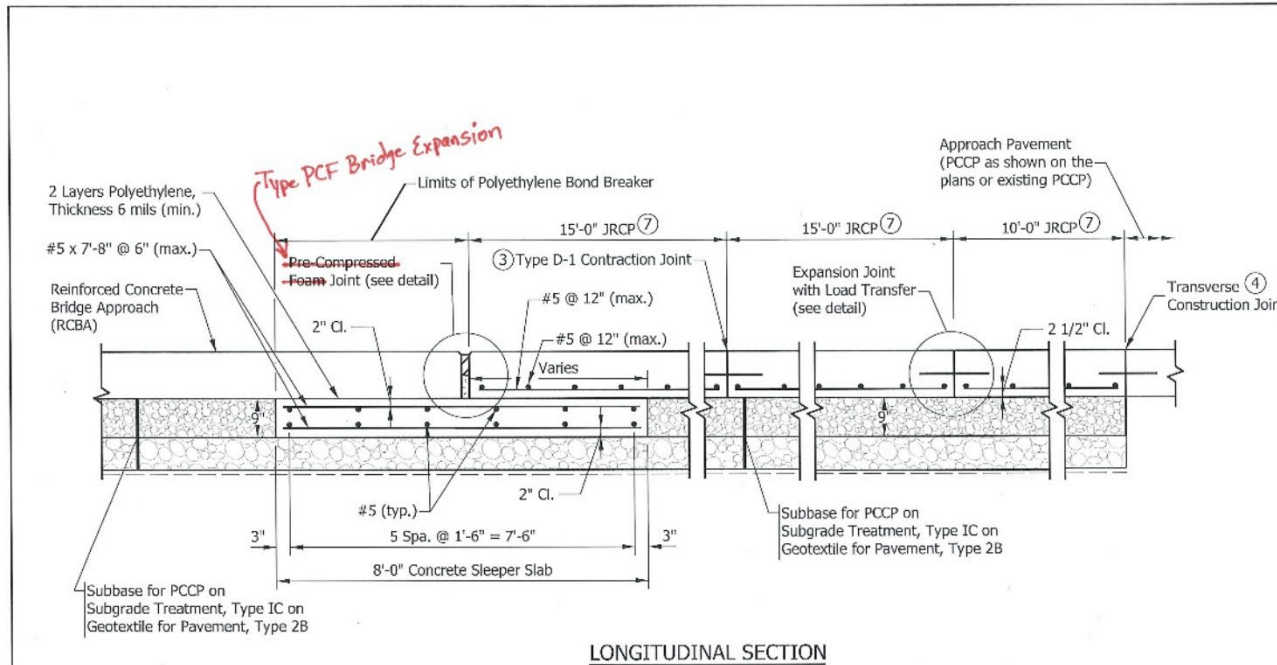

NOTES:

- ① The joint opening width shall be 2.5 in. for expansion lengths of 150 ft or less, regardless of the joint setting temperature. For expansion lengths greater than 150 ft, the joint opening width shall be constructed based on the actual ambient temperature at the time of construction with the manufacturer's joint setting table. The expansion length shall be as shown on the plans.
- ② The **Type PCF Bridge Expansion pre-compressed foam** joint shall be able to accommodate both the minimum and maximum joint opening widths as shown below.
 - Expansion length 250 ft or less
W(min.)=1.3 in.
W(max.)=3.7 in.
 - Expansion length greater than 250 ft and less than 400 ft.
W(min.)=1.0 in.
W(max.)=4.0 in.
- ③ See Standard Drawing series E 503-CCPJ for type D-1 contraction joint details.
- ④ See Standard Drawing series E 503-CCPJ for transverse construction joint details.
- ⑤ Expansion cap shall be placed with an air gap of 1/4 in. min. between end of dowel bar and end of cap. Expansion caps shall be placed on alternating end of the dowel bar.
- ⑥ Tining or grooving of the concrete shall be terminated 6 in. in advance of the joint opening.
- ⑦ Jointed Reinforced Concrete Pavement (JRCPC) thickness shall match the thickness of reinforced concrete bridge approach.
8. Underdrains shall be constructed when shown on the plans.

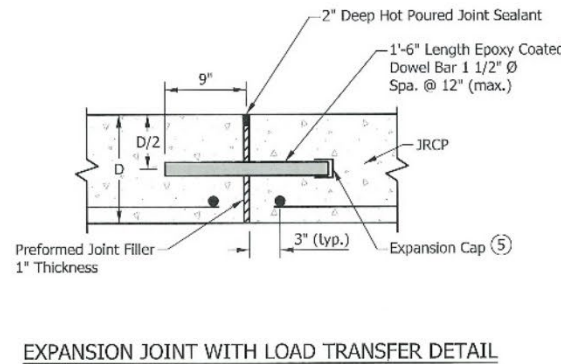
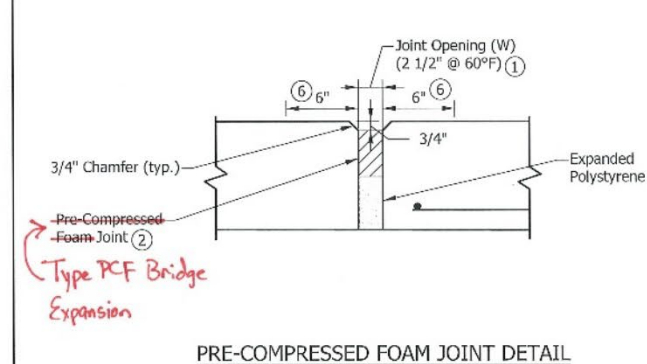

INDIANA DEPARTMENT OF TRANSPORTATION	
TERMINAL JOINT, TYPE PCCP	
SEPTEMBER 2022	
STANDARD DRAWING NO.	E 503-BATJ-02
	Subhi Bazlamit DESIGN STANDARDS ENGINEER 6/15/2022 DATE
Chief Engineer 06/27/2022 DATE	

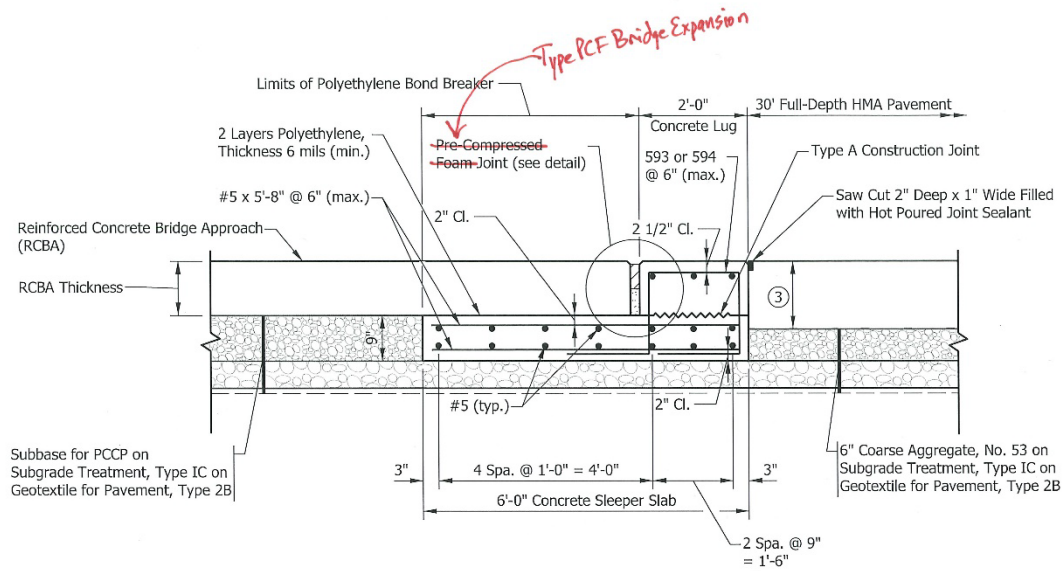

LONGITUDINAL SECTION

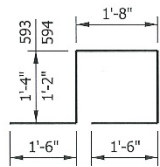

593 x 7'-4" (for 12" RCBA)
 594 x 7'-0" (for 10" RCBA)

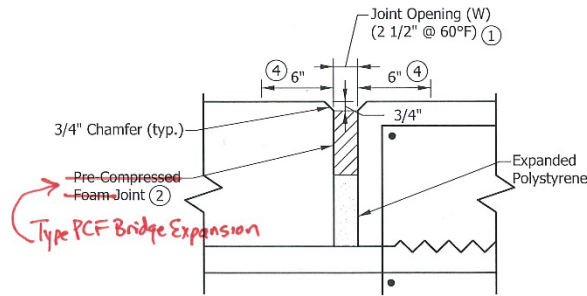

PRE-COMPRESSED FOAM JOINT DETAIL

NOTES:

- ① The joint opening width shall be 2.5 in. for expansion lengths of 150 ft or less, regardless of the joint setting temperature. For expansion lengths greater than 150 ft, the joint opening width shall be constructed based on the actual ambient temperature at the time of construction with the manufacturer's joint setting table. The expansion length shall be as shown on the plans.
- ② The ~~pre-compressed foam~~ *Type PCF Bridge Expansion* joint shall be able to accommodate both the minimum and maximum joint opening widths as shown below.
 - Expansion length 250 ft or less
 W(min.)=1.3 in.
 W(max.)=3.7 in.
 - Expansion length greater than 250 ft and less than 400 ft
 W(min.)=1.0 in.
 W(max.)=4.0 in.
- ③ Pavement section to be shown on the plans.
 Minimum Thickness:
 - 15 in. HMA for 12 in. RCBA
 - 13 in. HMA for 10 in. RCBA
- ④ Tining or grooving of the concrete shall be terminated 6 in. in advance of the joint opening.

INDIANA DEPARTMENT OF TRANSPORTATION

TERMINAL JOINT, TYPE HMA

SEPTEMBER 2022

STANDARD DRAWING NO. E 503-BATJ-03

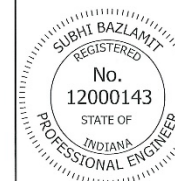

Subhi Bazlamit 6/15/2022
 DESIGN STANDARDS ENGINEER DATE

[Signature] 06/27/2022
 CHIEF ENGINEER DATE

REVISION TO 2022 STANDARD SPECIFICATIONS AND STANDARD DRAWINGS

E 724-BSSJ series EXPANSION JOINTS (WITH MARKUPS)

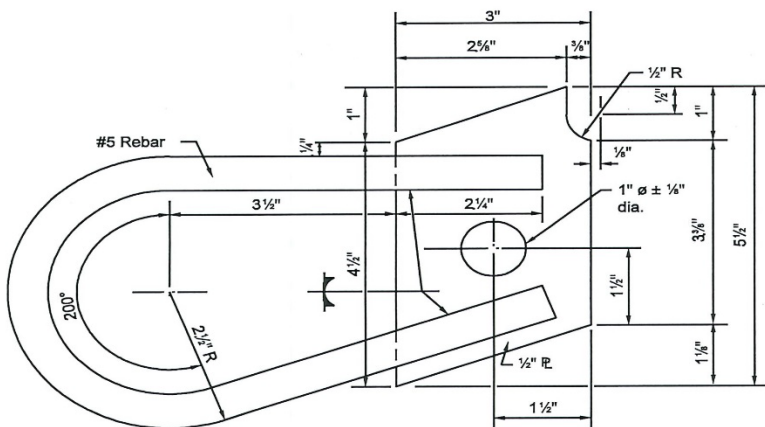

ANCHOR PLATE ALTERNATE A-1

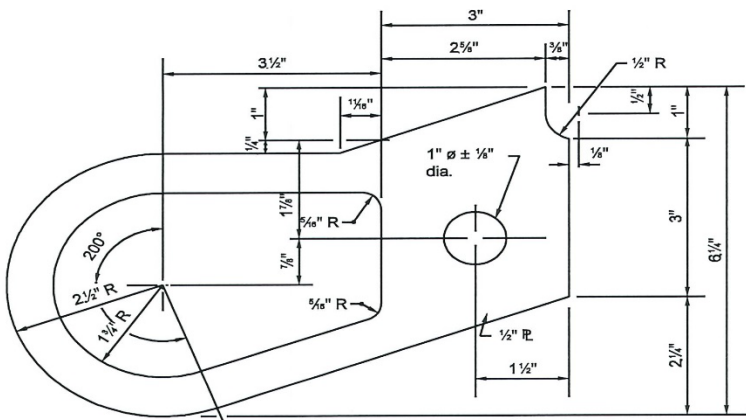

ANCHOR PLATE ALTERNATE A-2

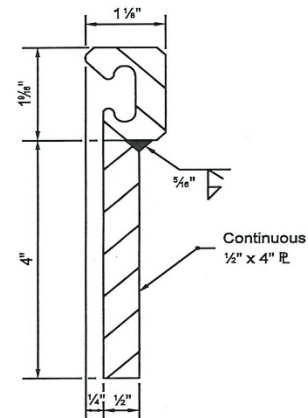

EXTRUSION & PLATE ASSEMBLY DETAIL

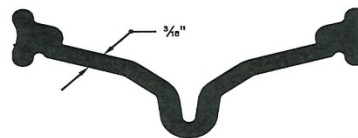

STRIP SEAL

TYPE

INDIANA DEPARTMENT OF TRANSPORTATION	
BRIDGE EXPANSION JOINTS	
→ CLASS SS (ALTERNATE A)	
SEPTEMBER 2003	
STANDARD DRAWING NO. E 724-BSSJ -01	
	/s/ Richard L. VanCleave 9-02-03 DESIGN STANDARDS ENGINEER DATE
	/s/ Richard K. Smutzer 9-02-03 CHIEF HIGHWAY ENGINEER DATE
DESIGN STANDARDS ENGINEER	

REVISION TO 2022 STANDARD SPECIFICATIONS AND STANDARD DRAWINGS

E 724-BSSJ series EXPANSION JOINTS (WITH MARKUPS)

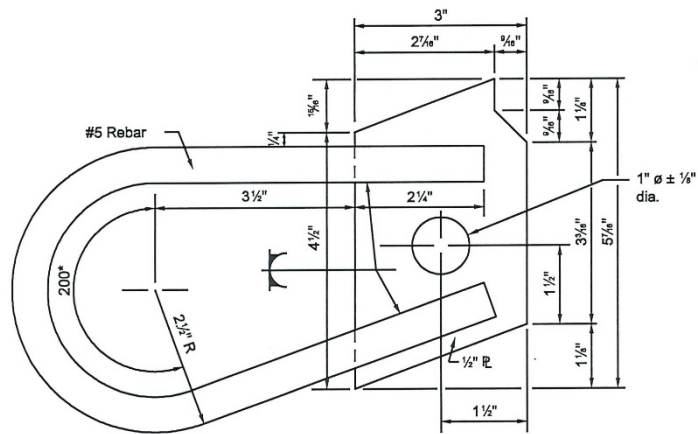

ANCHOR PLATE ALTERNATE B-1

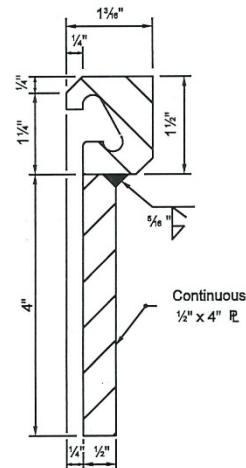

EXTRUSION & PLATE
ASSEMBLY DETAIL

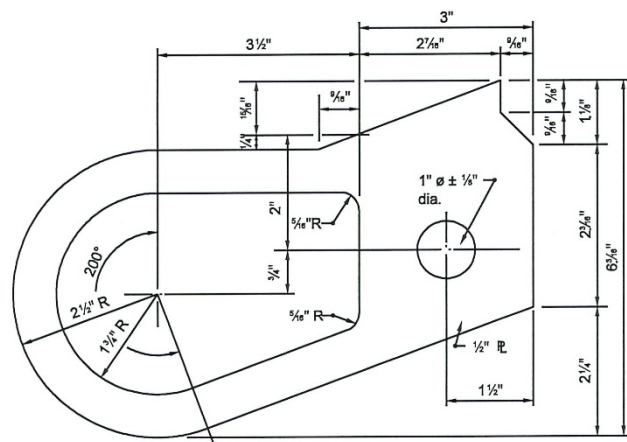

ANCHOR PLATE ALTERNATE B-2

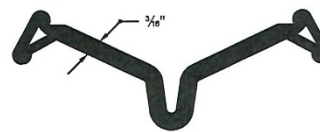

STRIP SEAL

INDIANA DEPARTMENT OF TRANSPORTATION	
BRIDGE EXPANSION JOINTS	
TYPE CLASS SS (ALTERNATE B)	
SEPTEMBER 2003	
STANDARD DRAWING NO. E 724-BSSJ -02	
	/s/ Richard L. VanCleave 9-02-03 DESIGN STANDARDS ENGINEER DATE
	/s/ Richard K. Smutzer 9-02-03 CHIEF HIGHWAY ENGINEER DATE

REVISION TO 2022 STANDARD SPECIFICATIONS AND STANDARD DRAWINGS

E 724-BSSJ series EXPANSION JOINTS (WITH MARKUPS)

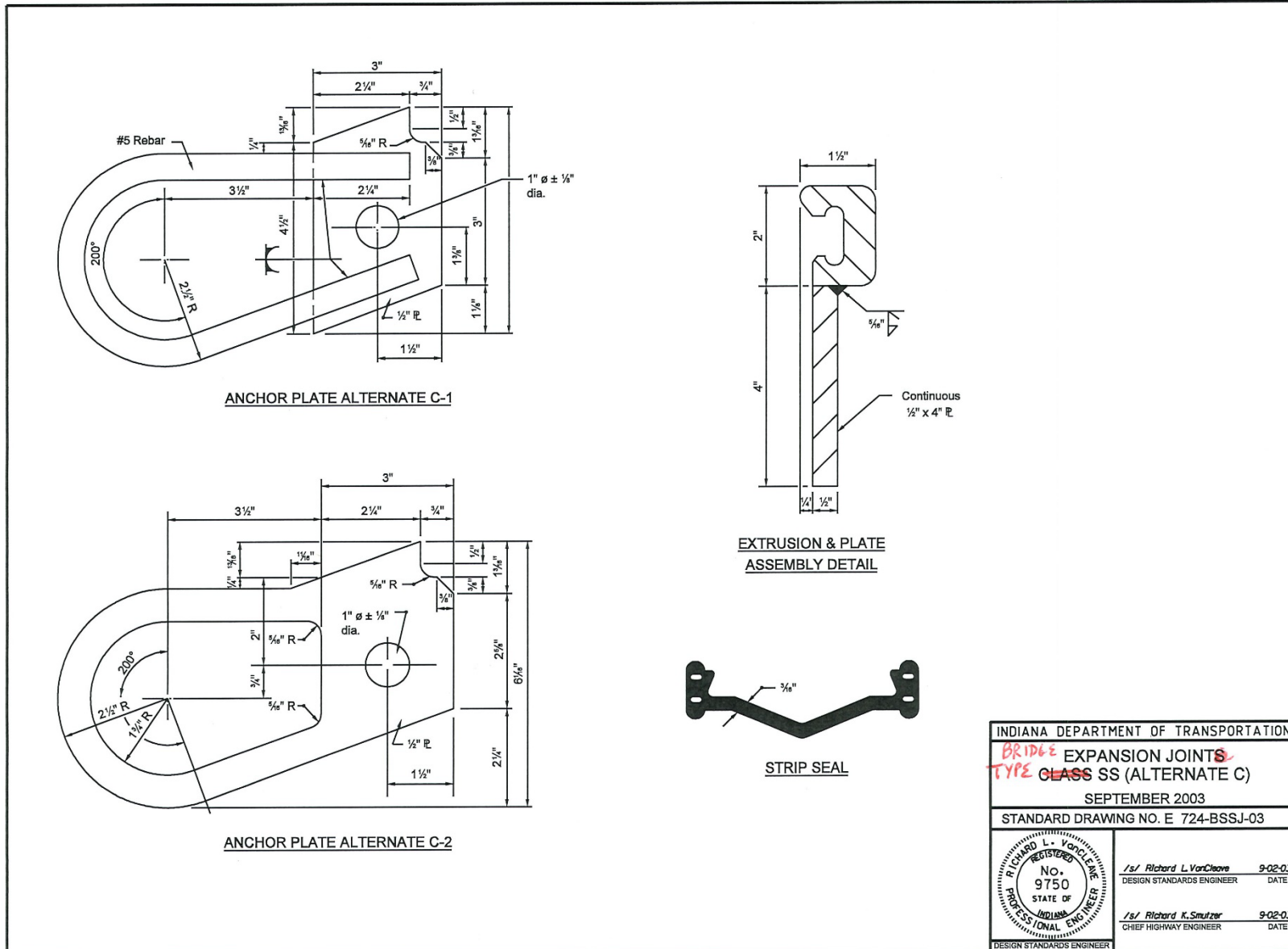

REVISION TO 2022 STANDARD SPECIFICATIONS AND STANDARD DRAWINGS

E 724-BSSJ series EXPANSION JOINTS (WITH MARKUPS)

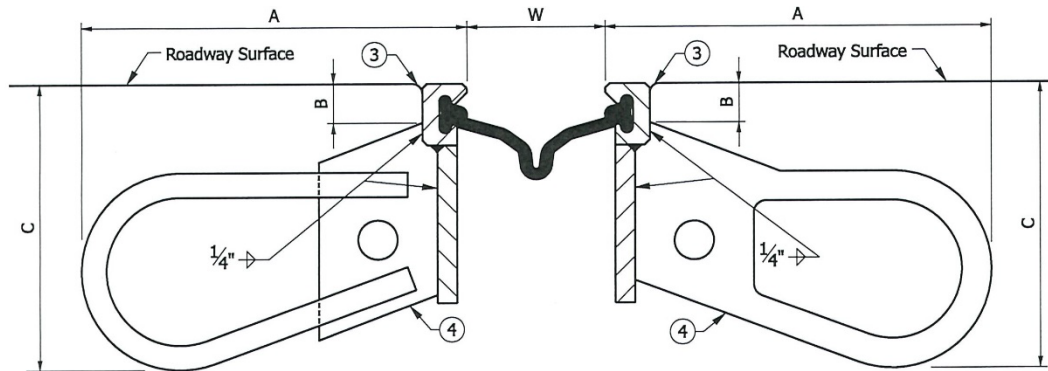

INSTALLATION DETAIL

GENERAL NOTES

1. This sheet shall be used in conjunction with Standard Drawing Nos. E 724-BSSJ-05 through 09.
2. Allowable expansion lengths shall not be increased for skewed structures.
- ③ Tool concrete edges to 1/4" to 3/8" radius.
- ④ Anchors shall be spaced at 9 in.

DIMENSIONS			
ALTERNATES	A	B	C
A-1	9 3/4"	1"	7 1/4"
A-2	9 3/4"	1"	7 1/4"
B-1	9 3/4"	1 5/16"	7 1/8"
B-2	9 3/4"	1 5/16"	7 1/8"
C-1	9 3/4"	1 13/16"	7 1/4"
C-2	9 3/4"	1 13/16"	7 1/4"
D-1	9 3/4"	1"	7 5/16"
D-2	9 3/4"	1"	7 5/16"

JOINT SETTING TABLE			
Ambient Temperature °F	DIMENSION "W"		
	Expansion Length		
	100'-200'	200'-300'	300'-400'
120°	2 1/8"	1 5/16"	1/2"
100°	2 7/16"	1 3/4"	1 1/8"
80°	2 1 1/16"	2 3/16"	1 11/16"
60°	3"	2 5/8"	2 1/4"
40°	3 5/16"	3 1/16"	2 13/16"
20°	3 3/16"	3 1/2"	3 3/8"
0°	3 7/8"	3 5/16"	4"

INDIANA DEPARTMENT OF TRANSPORTATION	
BRIDGE EXPANSION JOINTS TYPE CLASS SS	
SEPTEMBER 2007	
STANDARD DRAWING NO. E 724-BSSJ-04	
	/s/ Richard L. VanCleave 09/04/07 DESIGN STANDARDS ENGINEER DATE
	/s/ Mark A. Miller 09/04/07 CHIEF HIGHWAY ENGINEER DATE
DESIGN STANDARDS ENGINEER	

REVISION TO 2022 STANDARD SPECIFICATIONS AND STANDARD DRAWINGS

E 724-BSSJ series EXPANSION JOINTS (WITH MARKUPS)

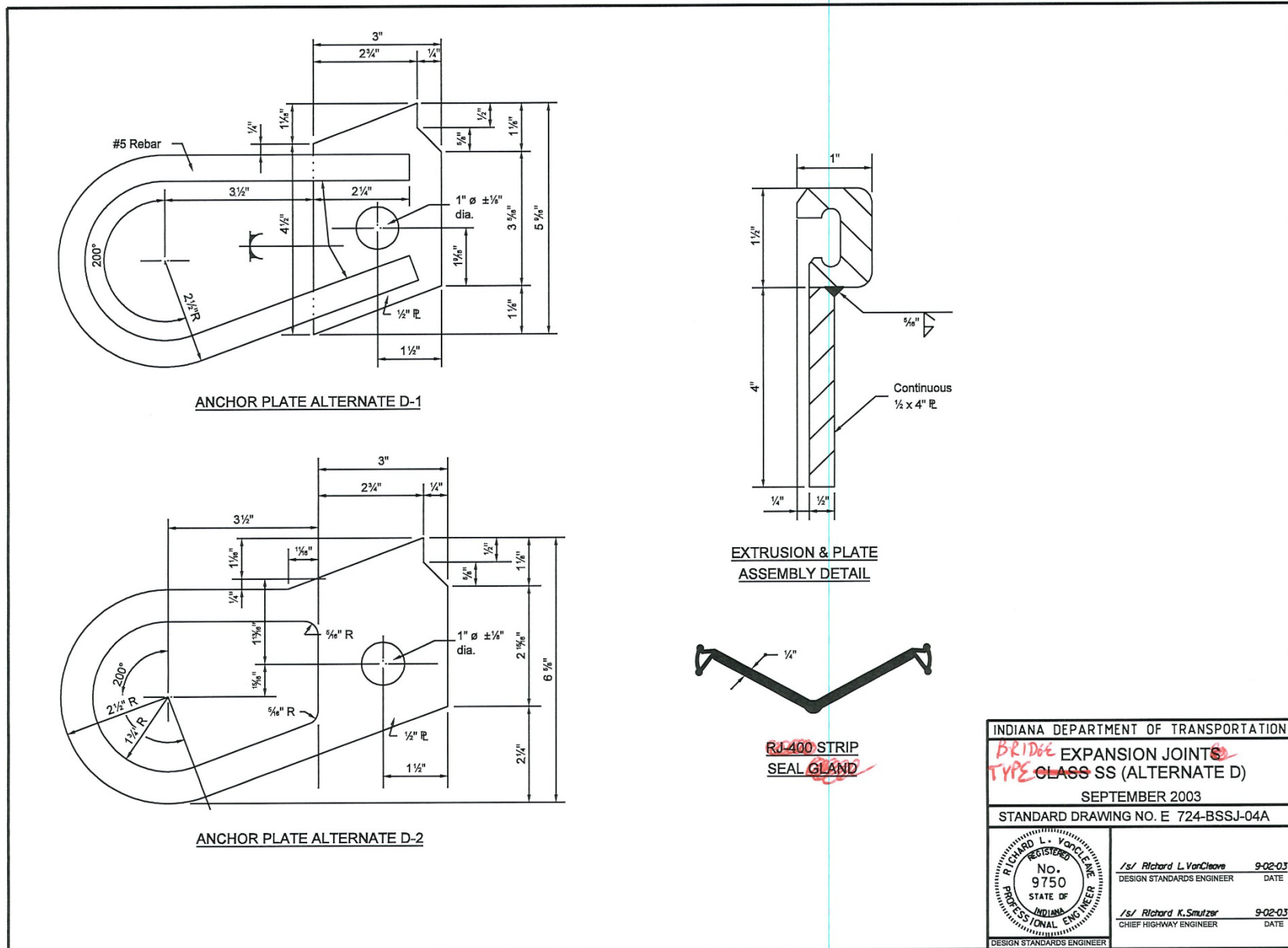

REVISION TO 2022 STANDARD SPECIFICATIONS AND STANDARD DRAWINGS

E 724-BSSJ series EXPANSION JOINTS (WITH MARKUPS)

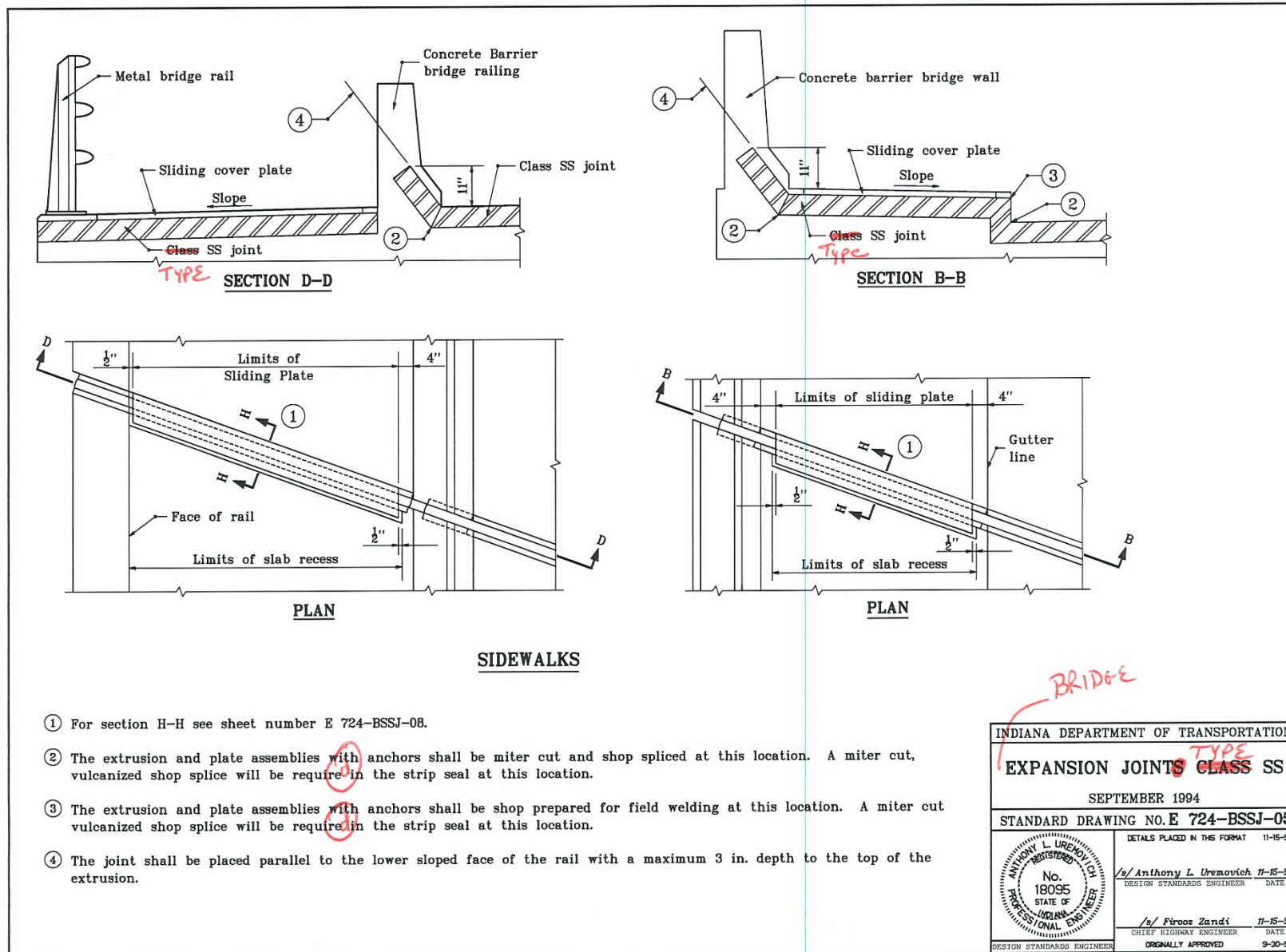

REVISION TO 2022 STANDARD SPECIFICATIONS AND STANDARD DRAWINGS

E 724-BSSJ series EXPANSION JOINTS (WITH MARKUPS)

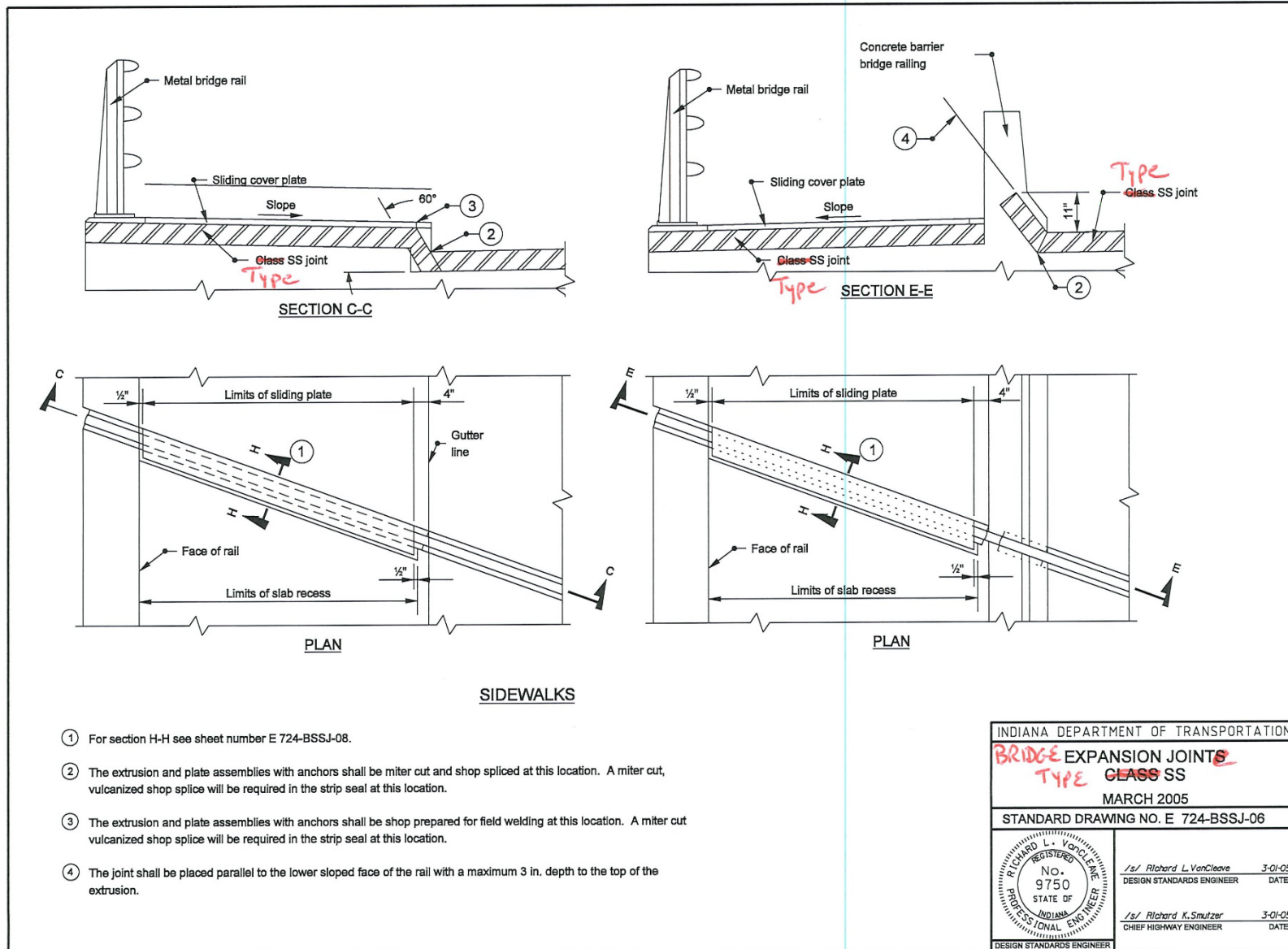

REVISION TO 2022 STANDARD SPECIFICATIONS AND STANDARD DRAWINGS

E 724-BSSJ series EXPANSION JOINTS (WITH MARKUPS)

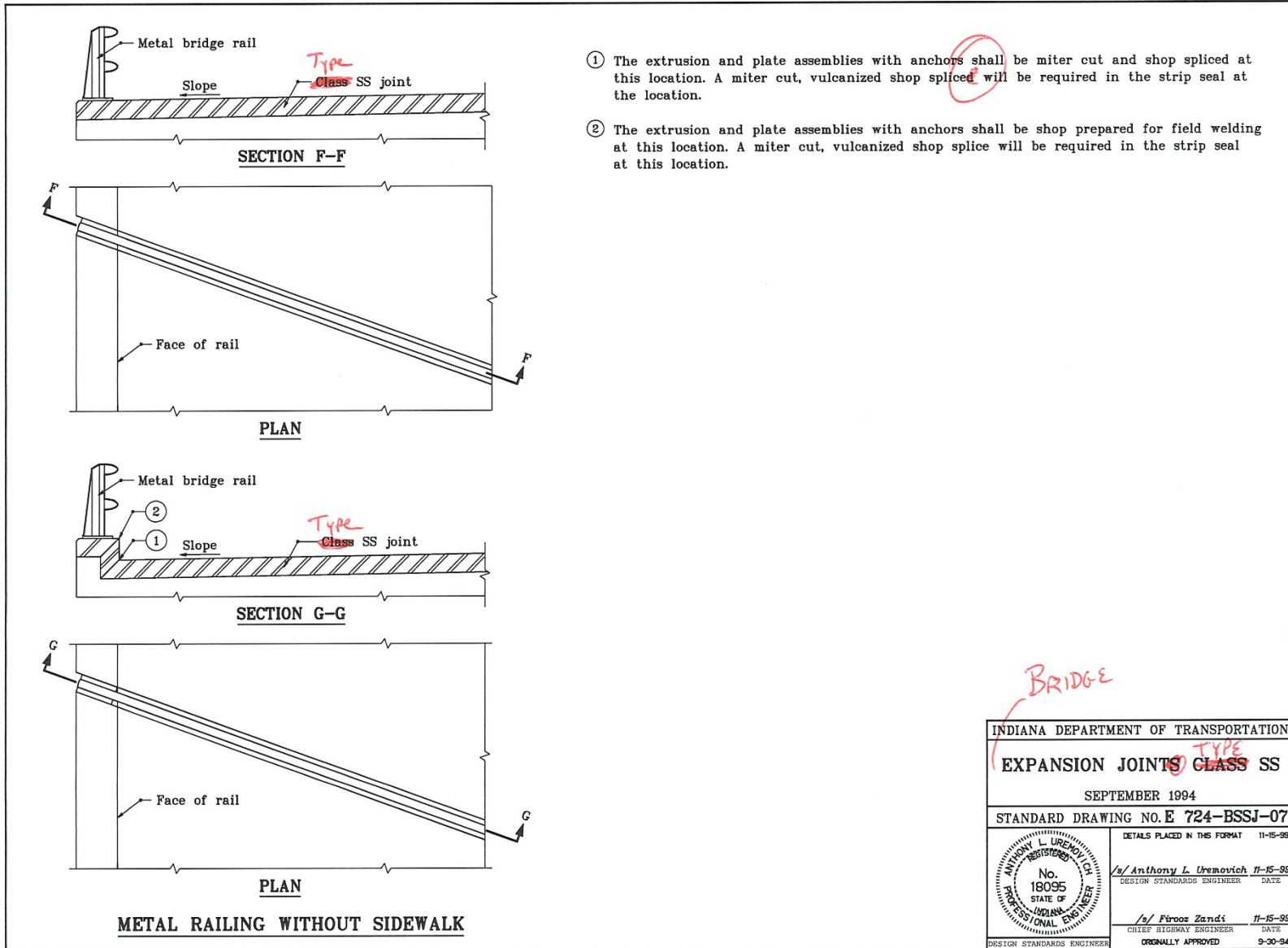

REVISION TO 2022 STANDARD SPECIFICATIONS AND STANDARD DRAWINGS

E 724-BSSJ series EXPANSION JOINTS (WITH MARKUPS)

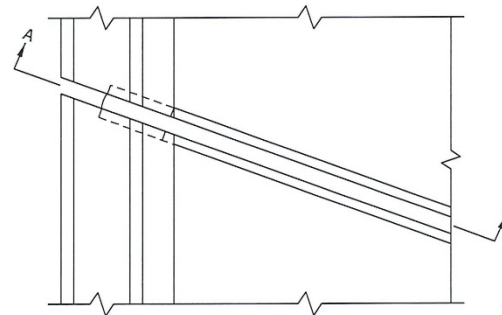
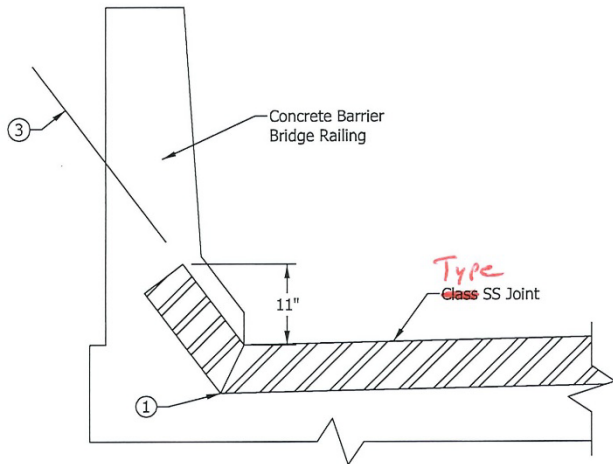
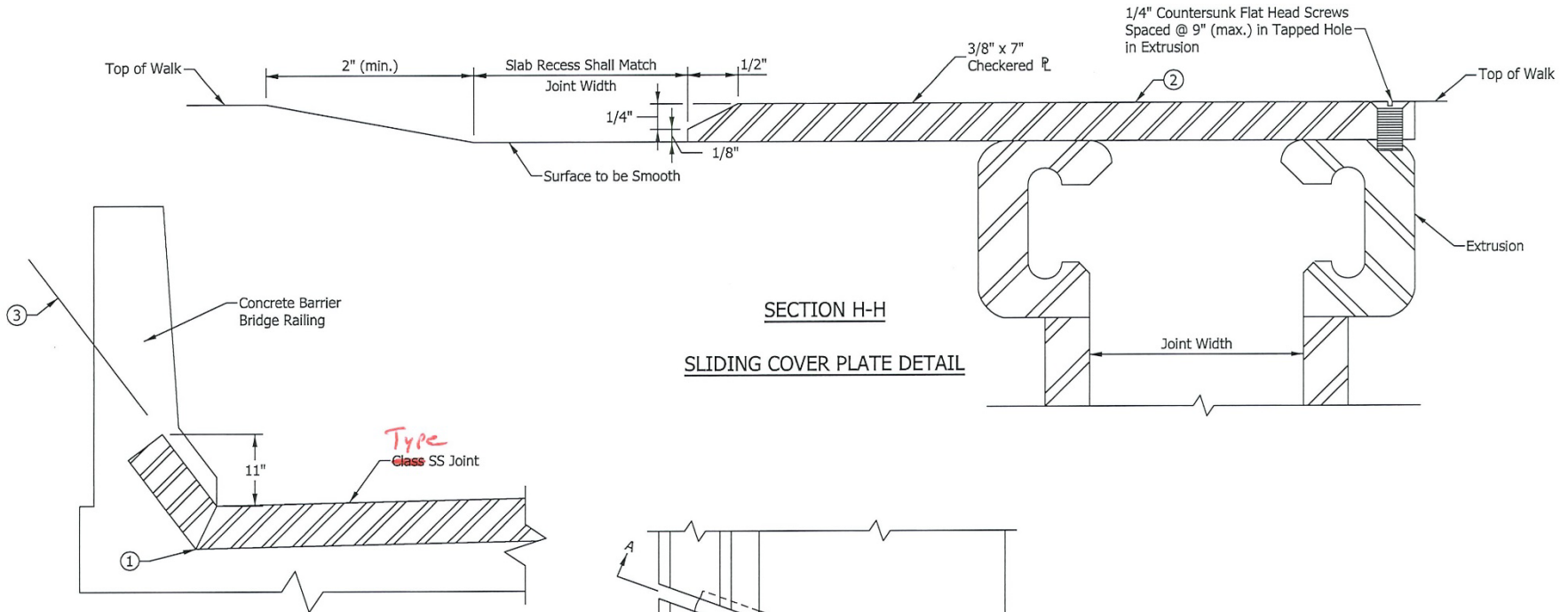

SECTION A-A

SECTION H-H

SLIDING COVER PLATE DETAIL

CONCRETE BARRIER BRIDGE RAILING

NOTES:

- ① The extrusion and plate assemblies with anchors shall be miter cut and shop spliced at this location. A miter cut, vulcanized shop splice will be required in the strip seal at this location.
- ② The length of the sliding cover plate, measured along the centerline of the ~~Class~~ ^{Type} SS Joint, shall be 3/8" shorter at each end than the limits of the recess as shown on these details.
- ③ The joint shall be placed parallel to the lower sloped face of the rail with a maximum 3" depth to the top of the extrusion.

INDIANA DEPARTMENT OF TRANSPORTATION	
BRIDGE EXPANSION JOINTS TYPE CLASS SS	
SEPTEMBER 2021	
STANDARD DRAWING NO. E 724-BSSJ-08	
	3/2/2021 DESIGN STANDARDS ENGINEER DATE
	03/17/2021 CHIEF ENGINEER DATE

REVISION TO 2022 STANDARD SPECIFICATIONS AND STANDARD DRAWINGS

E 724-BSSJ series EXPANSION JOINTS (WITH MARKUPS)

GENERAL NOTES

1. Standard Drawing Nos. E 724-BSSJ-05 through 09 shall be used in conjunction with Standard Drawing Nos. E 724-BSSJ-01 through 04.
2. The details shown on Standard Drawing Nos. E 724-BSSJ-05 through 09 are the only approved methods of placing ~~Class~~ SS Joints in curbs, sidewalks, concrete bridge railing and under metal bridge railing.
3. The locations of the anchor plates in sidewalks and in the concrete barrier bridge rail shall be as shown on the approved shop drawings but in no case shall the spacing exceed 9 in.

Type

BRIDGE

INDIANA DEPARTMENT OF TRANSPORTATION	
EXPANSION JOINTS CLASS ^{TYPE} SS	
SEPTEMBER 1994	
STANDARD DRAWING NO. E 724-BSSJ-09	
	DETAILS PLACED IN THIS FORMAT 11-15-99
/s/ Anthony L. Uremovich 11-15-99 DESIGN STANDARDS ENGINEER DATE	
/s/ Ferooz Zandi 11-15-99 CHIEF HIGHWAY ENGINEER DATE	
DESIGN STANDARDS ENGINEER	ORIGINALLY APPROVED 9-30-94

COMMENTS AND ACTION

503.02 Materials	724.02 Materials
503.03(e) Terminal Joints	724.03 General Requirements
503.07 Method of Measurement	906.07 Bridge Expansion Joints
503.08 Basis of Payment	E 503-BATJ-02, -03 Terminal Joint
724.01 Description	E 724-BSSJ series EXPANSION JOINT

DISCUSSION:

This item was introduced by Mr. Reilman who stated that various terms are used to refer to precompressed foam joints and other bridge expansion joints. Requirements for what is contained on the type B certification for Type SS and M joints is missing.

Mr. Reilman proposed to incorporate proposed changes to standardize the terminology used for bridge expansion joints as well as other minor clean-up revisions for clarity.

There was no further discussion and this item passed as submitted.

	Action:
Motion: Mr. Reilman	<input checked="" type="checkbox"/>
Second: Mr. White	<input type="checkbox"/>
Ayes: 10	<input type="checkbox"/>
Nays: 0	<input type="checkbox"/>
FHWA Approval: Yes	<input type="checkbox"/>
2022 Standard Specifications Sections referenced and/or affected: 503 begin pg 433, 724 begin pg 80, 906.07 begin pg 1016.	<input checked="" type="checkbox"/> 2024 Standard Specifications <input type="checkbox"/> Revise Pay Items List <input type="checkbox"/> Create RSP (No. __) Effective:
Recurring Special Provisions or Plan Details: NONE	<input type="checkbox"/> Revise RSP (No. __) Effective:
Standard Drawing affected: 503-BATJ series 724-BSSI series	<input checked="" type="checkbox"/> Standard Drawing: <u>503-BATJ series</u> <u>724-BSSI series</u> Effective: <u>September 1, 2023</u>
Design Manual Sections affected: TBD	<input type="checkbox"/> Create RPD (No. __) Effective:
GIFE Sections: TBD	<input type="checkbox"/> GIFE Update <input checked="" type="checkbox"/> Frequency Manual Update <input checked="" type="checkbox"/> SiteManager Update

PROPOSAL TO STANDARDS COMMITTEE

PROBLEM(S) ENCOUNTERED: INDOT has recently received precast structures that have been fabricated and delivered in several pieces and then spliced together in the field. This creates additional cold joints that complicate construction and will make the structures more susceptible to future deterioration. There have also been questions raised by Designers and Fabricators related to the level of detail that is required to be shown on the shop drawings of these structures.

PROPOSED SOLUTION: Sections 714 and 723 are proposed to be revised to prohibit the use of construction joints within the cross section that aren't shown on the contract plans, and to further define shop drawing expectations.

APPLICABLE STANDARD SPECIFICATIONS: 714.03, 714.04(c), 723.03, 723.04(c), 723.10, 723.14

APPLICABLE STANDARD DRAWINGS: N/A

APPLICABLE DESIGN MANUAL SECTION: Chapters 203 and 402 [No changes required]

APPLICABLE SECTION OF GIFE: N/A

APPLICABLE RECURRING SPECIAL PROVISIONS: 714-R-748

PAY ITEMS AFFECTED: N/A

APPLICABLE SUB-COMMITTEE ENDORSEMENT: Ad hoc committee comprised of Joe Novak and Jennifer Hart

IF APPROVED AS RECURRING SPECIAL PROVISION OR PLAN DETAILS, PROPOSED BASIS FOR USE: Projects that include 714 or 723 pay items

IMPACT ANALYSIS (attach report):

Submitted By: Pete White

Title: Design Manager

Division: Bridge Engineering

E-mail: pewwhite@indot.in.gov

Date: Oct. 21, 2022

IMPACT ANALYSIS REPORT CHECKLIST

Explain the business case as to why this item should be presented to the Standards Committee for approval. Answer the following questions with Yes, No or N/A.

Does this item appear in any other specification sections? No

Will approval of this item affect the Qualified Products List (QPL)? No

Will this proposal improve:

Construction costs? No
Construction time? Yes
Customer satisfaction? No
Congestion/travel time? No
Ride quality? No

Will this proposal reduce operational costs or maintenance effort? Yes

Will this item improve safety:

For motorists? No
For construction workers? No

Will this proposal improve quality for:

Construction procedures/processes? Yes
Asset preservation? Yes
Design process? Yes

Will this change provide the contractor more flexibility? No

Will this proposal provide clarification for the Contractor and field personnel? Yes

Can this item improve/reduce the number of potential change orders? Yes

Is this proposal needed for compliance with:

Federal or State regulations? No
AASHTO or other design code? No

Is this item editorial? No

Provide any further information as to why this proposal should be placed on the Standards Committee meeting Agenda:

REVISION TO 2022 STANDARD SPECIFICATIONS

SECTION 714 – REINFORCED CONCRETE BOX STRUCTURES

714.03 General Requirements

714.04 Design Requirements

SECTION 723 – REINFORCED CONCRETE THREE-SIDED STRUCTURES

723.03 General Requirements

723.04 Design Requirements

723.10 Pedestals

723.14 Joints

The Standard Specifications are revised as follows:

SECTION 714, BEGIN LINE 74, DELETE AND INSERT AS FOLLOWS:

714.03 General Requirements

Unless otherwise specified, the applicable requirements of 702 and 703 shall apply to the construction of box structures, structure extensions, and concrete parts of similar structures. Excavation and disposal shall be in accordance with the applicable requirements of 206. Areas designated for waterproofing shall be waterproofed in accordance with 702.23. All underground drains encountered during excavation for the structure shall be perpetuated as dictated by field conditions. Drainage openings through masonry shall be in accordance with 702.16. Handling of box structures shall be in accordance with 907.05. Handling of wingwalls shall be in accordance with 907.06.

When riprap is specified, geotextile shall first be placed on the in-situ soil in accordance with 616.11. Riprap shall then be placed in accordance with 616.

The box structure, headwalls, wingwalls, and footings shall be designed and constructed in accordance with the dimensions shown on the contract plans. Construction joints shall not be used within the cross-section of precast box structures.

SECTION 714, BEGIN LINE 136, DELETE AND INSERT AS FOLLOWS:

(c) Working Drawings

Working drawings shall be submitted in accordance with 105.02 for:

1. fabrication of a precast reinforced concrete box structure greater than 12 ft span,
2. a box structure of a size not ~~described~~ shown in ASTM C1577, Table 1,
3. headwalls,
4. wingwalls, and
5. footings.

Design calculations shall be submitted with the working drawings. ~~Design calculations are will not be required for box structures that are designed and constructed in accordance with~~ of a size shown in Table 1 of ASTM C1577. Detailed plans for falsework and centering will not be required. Working drawings shall include *notes indicating design assumptions, applicable design codes, and material requirements*, all details, dimensions, and quantities necessary to construct the structure, headwalls, wingwalls, or footings and shall include, but not be limited to, the following information.

REVISION TO 2022 STANDARD SPECIFICATIONS

SECTION 714 – REINFORCED CONCRETE BOX STRUCTURES

714.03 General Requirements

714.04 Design Requirements

SECTION 723 – REINFORCED CONCRETE THREE-SIDED STRUCTURES

723.03 General Requirements

723.04 Design Requirements

723.10 Pedestals

723.14 Joints

1. Structure span and rise.
2. Structure section details showing all concrete dimensions, *joint details, locations and details of lifting devices or inserts, locations and details of pre or post-installed anchorages, concrete clear cover, size and spacing of reinforcing bars or WWR, and reinforcing bar bending diagrams and reinforcement requirements.*

SECTION 723, BEGIN LINE 89, DELETE AND INSERT AS FOLLOWS:

723.03 General Requirements

Excavation and disposal shall be in accordance with the applicable requirements of 206. The areas designated for waterproofing shall be waterproofed in accordance with 702.23. All underground drains encountered during excavation for the structure shall be perpetuated as dictated by field conditions. Drainage openings through masonry shall be in accordance with 702.16. Handling of three-sided structures shall be in accordance with 907.05. Handling of wingwalls and spandrel walls shall be in accordance with 907.06.

For precast three-sided structures, the manufacturer's representative shall provide technical instruction and on-site technical assistance to the Contractor during the erection of the members.

The three-sided structure, headwalls, wingwalls, and footings shall be designed and constructed in accordance with the dimensions shown on the contract plans. Construction joints shall not be used within the cross-section of precast three-sided structures unless shown on the contract plans.

SECTION 723, BEGIN LINE 159, DELETE AND INSERT AS FOLLOWS:

(c) Working Drawings

Working drawings shall be submitted in accordance with 105.02 for fabrication of a precast or cast-in-place reinforced concrete three-sided structure, precast or cast-in-place reinforced concrete three-sided structure extension, precast or cast-in-place headwalls, precast or cast-in-place wingwalls, and precast or cast-in-place spandrel walls. The working drawings shall include *notes indicating design assumptions, applicable design codes, and material requirements*, all details, dimensions, and quantities necessary to construct the structure, headwalls, wingwalls, or spandrel walls and shall include, but not be limited to, the following information.

1. Structure span and rise.

REVISION TO 2022 STANDARD SPECIFICATIONS

SECTION 714 – REINFORCED CONCRETE BOX STRUCTURES

714.03 General Requirements

714.04 Design Requirements

SECTION 723 – REINFORCED CONCRETE THREE-SIDED STRUCTURES

723.03 General Requirements

723.04 Design Requirements

723.10 Pedestals

723.14 Joints

2. Structure section details showing all concrete dimensions *joint details, locations and details of lifting devices or inserts, locations and details of pre or post-installed anchorages, concrete clear cover, size and spacing of reinforcing bars or WWR, and reinforcing bar bending diagrams* and reinforcement requirements. An analysis of the precast segment modeled as a simple span and designed in accordance with AASHTO LRFD Bridge Design Specifications Section 5.7.3. This analysis shall demonstrate that the precast segment is designed to withstand the forces of erection. Details for providing horizontal restraint of the structure legs during installation until after the completion of backfill placement shall be included unless the analysis indicates such details are not needed.

SECTION 723, BEGIN LINE 278, INSERT AS FOLLOWS:

723.10 Pedestals

Where a reinforced concrete pedestal is required between the base of the structure leg and the top of the footing *to provide the required top of footing elevation rise and low structure elevation as shown on the contract plans*, the Contractor shall have the option of providing a structure with extended legs or constructing the pedestals.

SECTION 723, BEGIN LINE 395, INSERT AS FOLLOWS:

723.14 Precast Reinforced-Concrete Three-Sided Structure Section Joints

COMMENTS AND ACTION

- 714.03 General Requirements
- 714.04 Design Requirements
- 723.03 General Requirements
- 723.04 Design Requirements
- 723.10 Pedestals
- 723.14 Joints

DISCUSSION:

This item was introduced and presented by Mr. White, who explained that the Department has recently received precast structures that have been fabricated and delivered in several pieces and then spliced together in the field. This creates additional cold joints that complicate construction and will make the structures more susceptible to future deterioration. There have also been questions raised by Designers and Fabricators related to the level of detail that is required to be shown on the working drawings of these structures.

Mr. White proposed that Sections 714 and 723 be revised to prohibit the use of construction joints within the cross-section that aren't shown on the contract plans, and to further define working drawing expectations. Further revisions by Mr. White are as shown.

There was no further discussion and this item passed as revised.

<p>Motion: Mr. White Second: Mr. Reilman Ayes: 10 Nays: 0 FHWA Approval: Yes</p>	<p>Action:</p> <p>— Passed as Submitted <input checked="" type="checkbox"/> Passed as Revised — Withdrawn</p>
<p>2022 Standard Specifications Sections referenced and/or affected: 714 pg. 723 and 724; 723 pg. 792, 794, 797, and 799.</p>	<p><input checked="" type="checkbox"/> 2024 Standard Specifications Revise Pay Items List</p> <p><input checked="" type="checkbox"/> Create RSP (No. 714-R-755 and 723-R-756) Effective: June 1, 2023</p>
<p>Recurring Special Provisions or Plan Details: 714-R-748 Waterproofing Membrane for Reinforced-Concrete Box Structures and Three-Sided Structures</p>	<p><input checked="" type="checkbox"/> Revise RSP (No. 714-R-748) Effective: June 1, 2023</p>
<p>Standard Drawing affected: NONE</p>	<p>— Standard Drawing Effective:</p>
<p>Design Manual Sections affected: Chapters 203 and 402 [No changes required]</p>	<p>— Create RPD (No. __) Effective:</p>
<p>GIFE Sections cross-references: NONE</p>	<p>— GIFE Update — Frequency Manual Update — SiteManager Update</p>

PROPOSAL TO STANDARDS COMMITTEE

PROBLEM(S) ENCOUNTERED: The Department's Buy America specification requirements need to be updated to comply with the new Federal requirements.

PROPOSED SOLUTION: Incorporate the proposed edits to bring the Department's specifications into line with the new Federal requirements

APPLICABLE STANDARD SPECIFICATIONS: 106, 914, 916

APPLICABLE STANDARD DRAWINGS: None

APPLICABLE DESIGN MANUAL SECTION: None

APPLICABLE SECTION OF GIFE:

APPLICABLE RECURRING SPECIAL PROVISIONS: create new RSP

PAY ITEMS AFFECTED: None

APPLICABLE SUB-COMMITTEE ENDORSEMENT: Ad Hoc: Derrick Hauser, Jon Korff, Kurt Pelz, Jim Reilman

IF APPROVED AS RECURRING SPECIAL PROVISION OR PLAN DETAILS, PROPOSED BASIS FOR USE:
Required for all Federal Aid contracts

IMPACT ANALYSIS (attach report):

Submitted By: Jim Reilman

Title: State Materials Engineer

Organization: INDOT

Phone Number: (317) 522-9692

Date: 10/24/22

IMPACT ANALYSIS REPORT CHECKLIST

Explain the business case as to why this item should be presented to the Standards Committee for approval. Answer the following questions with Yes, No or N/A.

Does this item appear in any other specification sections? No

Will approval of this item affect the Approved Materials List? No

Will this proposal improve:

Construction costs? No

Construction time? No

Customer satisfaction? N/A

Congestion/travel time? N/A

Ride quality? N/A

Will this proposal reduce operational costs or maintenance effort? N/A

Will this item improve safety:

For motorists? N/A

For construction workers? N/A

Will this proposal improve quality for:

Construction procedures/processes? N/A

Asset preservation? N/A

Design process? N/A

Will this change provide the contractor more flexibility? No

Will this proposal provide clarification for the Contractor and field personnel? Yes

Can this item improve/reduce the number of potential change orders? N/A

Is this proposal needed for compliance with:

Federal or State regulations? Yes

AASHTO or other design code? No

Is this item editorial? No

Provide any further information as to why this proposal should be placed on the Standards Committee meeting Agenda:

REVISION TO SPECIAL PROVISIONS

106-C-XXX BUILD AMERICA, BUY AMERICA ACT REQUIREMENTS (proposed new)

106-C-xxx BUILD AMERICA, BUY AMERICA ACT REQUIREMENTS

(Adopted xx-xx-xx)

The Standard Specifications are revised as follows:

SECTION 106, BEGIN LINE 81, DELETE AND INSERT AS FOLLOWS:

(c) Build America, Buy America Requirements

All contracts shall be supplied with steel and iron products *and construction materials* that are ~~made~~*produced* in the United States. ~~and~~*Steel and iron products* shall comply with IC 5-16-8 and the 23 CFR 635.410.

A Build America, Buy America Certification shall be submitted and received for each product or source of material prior to being incorporated into the contract in accordance with 916.02(e) and 916.03(e).

1. Steel and Iron Products

All steel ~~and~~ iron products incorporated permanently into a contract shall be made of steel or iron produced in the United States and all subsequent manufacturing shall be performed in the United States except for pig iron and processed, pelletized, and reduced iron ore. Manufacturing is any process that modifies the chemical content; physical shape or size; or final finish of a product. Manufacturing begins with the initial melting and mixing and continues through the bending and coating stages. If a domestic product is taken out of the United States for any process, it becomes a foreign source material.

Manufactured products that are partially or predominantly steel, shall be entirely produced with domestic steel. If a product has miscellaneous foreign steel incorporated, such as fasteners or brackets, then those miscellaneous pieces shall be replaced or substituted.

1a. Exceptions

The Engineer may grant specific written permission to use foreign steel or iron products when both of the following conditions apply:

~~a~~(1) The total cost of all foreign products to be used does not exceed 0.1 percent of the total Contract cost, or \$2,500, whichever is greater. The cost is the value of the product as delivered to the project.

~~b~~(2) The specified products are not produced in the United States in sufficient quantity or otherwise are not reasonably available to meet the requirements of the Contract Documents. ~~The Engineer may require the Contractor to obtain letters from three different suppliers documenting the unavailability of a product from a domestic source if the shortage is not previously established by the Department. The Department will request a waiver when domestic iron and steel, of~~

REVISION TO SPECIAL PROVISIONS

106-C-XXX BUILD AMERICA, BUY AMERICA ACT REQUIREMENTS (proposed new)

satisfactory quality, are not produced in sufficient and reasonably available quantities.

2. Construction Materials

All construction materials incorporated permanently into a contract that serve an ongoing need to the finished product shall be manufactured in the United States. All manufacturing processes for the construction materials shall occur in the United States.

~~A Buy America Certification shall be submitted and received for each product or source of material prior to being incorporated into the contract in accordance with 916.02(g) and 916.03(a).~~

SECTION 106, BEGIN LINE 239, DELETE AND INSERT AS FOLLOWS:

106.11 Sample Asbestos Exclusion Letter

Asbestos-containing materials shall not be used in the construction or reconstruction of buildings or bridges. A letter of exclusion for each building or bridge shall be submitted by the Contractor to the Engineer prior to acceptance of work and final payment. Such letter shall indicate that no asbestos-containing material was used as a building material during the project using the exclusion form in 916.03(f)04.

SECTION 914, BEGIN LINE 64, DELETE AND INSERT AS FOLLOWS:

The seed supplier shall provide *an other type* certification in accordance with 916.02 and ~~916.03(g)~~ that lists the seed lots used in the mixture and shall indicate that the seed mixture supplied meets the contract requirements for the specific contract that the particular seed mixture is supplied. Also, as part of the certification, the seed supplier shall provide a copy of the State Seed Commissioner's letter for the seed mixture that shows that each seed lot has been tested and found to be satisfactory. The specific test results for each seed lot shall also be attached to the certification.

SECTION 916, BEGIN LINE 21, DELETE AND INSERT AS FOLLOWS:

916.02 Types of Certifications

Certifications shall be type A, type B, type C, type D, *Build America, Buy America*, or as required under other types. When specified, the type of certification provided for a material shall be in accordance with the Frequency Manual except as otherwise specified. Specific information and test results required in type A, type B, and other types of certifications will be listed in the material specifications. Sample forms for type A, type B, type C, and type D, and *Build America, Buy America* certifications are shown in 916.03. Sample forms for other type certifications are shown in ~~916.03 or~~ ITM 804.

SECTION 916, AFTER LINE 56, DELETE AND INSERT AS FOLLOWS:

(e) Build America, Buy America Requirement

All steel and iron materials and products and construction materials used in the contract shall be certified to be in accordance with 106.01(c).

(e)f) Other Types

Types of certifications other than types A, B, C, and D are specified for selected

REVISION TO SPECIAL PROVISIONS

106-C-XXX BUILD AMERICA, BUY AMERICA ACT REQUIREMENTS (proposed new)

materials. The requirements for a certification, other are described in the respective material's specification. ~~A s~~ Samples ~~is~~are shown in ITM 804.

(f) Requirements for Small Quantities of Materials

Where circumstances warrant, *as determined by the Department*, and previously ~~approved~~ acceptable material is not available, small quantities may be accepted either by a type D certification or by an affidavit from the supplier stating that the material offered is equal to that specified.

(g) Buy America Requirement

~~All steel and cast iron materials and products used in the contract shall be certified to be in accordance with 106.01(c).~~

916.03 Sample Forms

(a) For Buy America Requirement

BUY AMERICA CERTIFICATION

~~In accordance with Indiana Department of Transportation Specification 106.01(c), I hereby certify that all steel and cast iron materials and products were produced and manufactured in the United States of America or territories subject to its jurisdiction.~~

CONTRACT NUMBER _____

PROJECT NUMBER _____

CONTRACTOR'S NAME _____

MANUFACTURER'S NAME _____

B/L or INVOICE NUMBER _____

This is to certify that for the contract described above, the materials supplied are as follows:

**** Material Name**

Quantity

Date

Company of Manufacture

*** Signature of Company Official/Title**

Date

Contractor

REVISION TO SPECIAL PROVISIONS

106-C-XXX BUILD AMERICA, BUY AMERICA ACT REQUIREMENTS (proposed new)

Signature of Contractor Official/Title

~~* This Certification shall be prepared by the manufacturer of the material being supplied for this contract.~~

~~** Identifying information such as Alloy, Grade, Type, Class, or other similar designation shall also be shown when appropriate.~~

(ba) Sample Type A Certification Form

INDIANA DEPARTMENT OF TRANSPORTATION

TYPE A CERTIFICATION OF COMPLIANCE

CONTRACT NUMBER _____

PROJECT NUMBER _____

CONTRACTOR'S NAME _____

MANUFACTURER'S NAME _____

B/L or INVOICE NUMBER _____

This is to certify that for the contract described above, the materials supplied are as follows:

** Material Name	Quantity
_____	_____
_____	_____

*** Conform to: _____

The materials listed above comply with the following Test Methods and are within the acceptable limits of said Test Methods:

TEST METHOD	LIMITS OF TEST VALUE	ACTUAL TEST RESULTS
_____	_____	_____
_____	_____	_____
_____	_____	_____

Date

Company of Manufacture

* Signature of Company Official/Title

* This Certification shall be prepared by the manufacturer of the material being

REVISION TO SPECIAL PROVISIONS

106-C-XXX BUILD AMERICA, BUY AMERICA ACT REQUIREMENTS (proposed new)

supplied for this contract.

** Identifying information such as Alloy, Grade, Type, Class, or other similar designation shall also be shown when appropriate.

*** Applicable material specification reference shall be listed.

(eb) Sample Type B Certification Form

INDIANA DEPARTMENT OF TRANSPORTATION

TYPE B CERTIFICATE OF COMPLIANCE

CONTRACT NUMBER _____

PROJECT NUMBER _____

CONTRACTOR'S NAME _____

MANUFACTURER'S NAME _____

B/L or INVOICE NUMBER _____

This is to certify that for the contract described above, the materials supplied are as follows:

** Material Name	Quantity
_____	_____
_____	_____

*** Conform to: _____

The materials listed above comply with the following Test Methods and are within the acceptable limits of said Test Methods.

TEST METHOD	LIMITS OF TEST VALUE
_____	_____
_____	_____
_____	_____

Date

Company of Manufacture

* _____
* Signature of Company Official/Title

* This Certification shall be prepared by the manufacturer of the material being supplied for this contract.

** Identifying information such as Alloy, Grade, Type, Class, or other similar

REVISION TO SPECIAL PROVISIONS

106-C-XXX BUILD AMERICA, BUY AMERICA ACT REQUIREMENTS (proposed new)

designation shall also be shown when appropriate.

*** Applicable material specification reference shall be listed.

(dc) Sample Type C Certification Form

CONTRACT NUMBER _____

PROJECT NUMBER _____

CONTRACTOR'S NAME _____

MANUFACTURER'S NAME _____

B/L or INVOICE NUMBER _____

This is to certify that for the contract described above, the materials supplied are as follows:

**Material Name	Quantity
_____	_____
_____	_____

*** Conform to: _____

_____	_____
Date	Company of Manufacture

* _____
* Signature of Company Official/Title

* This Certification shall be prepared by the manufacturer of the material being supplied for this contract.

** Identifying information such as Alloy, Grade, Type, Class, or other similar designation shall also be shown when appropriate.

*** Applicable material specification reference shall be listed.

(ed) Sample Type D Certification Form

CONTRACT NUMBER _____

PROJECT NUMBER _____

MANUFACTURER'S NAME _____

This is to certify that for the contract described above, the materials supplied are as follows:

REVISION TO SPECIAL PROVISIONS

106-C-XXX BUILD AMERICA, BUY AMERICA ACT REQUIREMENTS (proposed new)

**Material Name	Quantity
_____	_____
_____	_____

*** Is in accordance with: _____

_____	_____
Date	Contractor

* _____
* Signature of Contractor Official/Title

- * This Certification shall be prepared by the Contractor.
- ** Identifying information such as Alloy, Grade, Type, Class, or other similar designation shall also be shown when appropriate.
- *** Applicable material specification reference shall be listed. Otherwise, a statement shall be provided that the material supplied is in accordance with minimum trade standards.

(e) Sample Build America, Buy America Certification Form

BUILD AMERICA, BUY AMERICA CERTIFICATION

This Certification shall be prepared by the manufacturer of the product and material being supplied for this contract.

CONTRACT NUMBER _____

PROJECT NUMBER _____

CONTRACTOR'S NAME _____

MANUFACTURER'S NAME _____

BILL OF LADING or INVOICE NUMBER _____

1. Steel and Iron Materials and Products

In accordance with 106.01(c)1, I hereby certify that all steel and iron materials and products listed below were produced and manufactured in the United States of America or territories subject to its jurisdiction.

<i>Material Name*</i>	<i>Quantity (units)</i>	<i>Company of Manufacture</i>
_____	_____	_____
_____	_____	_____

REVISION TO SPECIAL PROVISIONS

106-C-XXX BUILD AMERICA, BUY AMERICA ACT REQUIREMENTS (proposed new)

_____	_____	_____
-------	-------	-------

* Identifying information such as Alloy, Grade, Type, Class, or other similar designation shall also be shown when appropriate.

2. Construction Materials

In accordance with 106.01(c)2, I hereby certify that all construction materials listed below and all manufacturing processes for the construction materials listed below occurred in the United States of America or territories subject to its jurisdiction.

Material Name*	Quantity (units)	Company of Manufacture
_____	_____	_____
_____	_____	_____
_____	_____	_____

* Identifying information shall be shown when appropriate.

Signature of Company Official

Title

Date _____

Signature of Contractor Official

Title

Date _____

(§)916.04 Sample Asbestos Exclusion Letter

Prior to acceptance of work and final payment, the Contractor shall submit to the Engineer for each building or bridge, on the Contractor's letterhead, a signed, dated copy of the following letter. The Engineer will be responsible for the distribution of the letter.

ASBESTOS EXCLUSION LETTER

Date

work address of Engineer for Indiana Department of Transportation

ATT: _____
Name, Project Engineer/Supervisor

Re: Asbestos Exclusion
Location/Description _____
Contract Number _____

REVISION TO SPECIAL PROVISIONS

106-C-XXX BUILD AMERICA, BUY AMERICA ACT REQUIREMENTS (proposed new)

Bridge Structure Number _____

Contractor's Name _____

Dear Engineer:

I hereby certify that to the best of my knowledge no asbestos containing material was used as a building material in this project.

Very truly yours,

Signature of Contractor official

Title of Contractor official

cc: District Bridge Inspection Engineer
~~Environment, Planning and Engineering Division Chief~~ *Environmental Services*
Director
Project File

~~(g) Sample Type Other Certification Form~~

~~SEED CERTIFICATION~~

~~This is to certify that the seed mixture supplied, _____, by _____ (name of seed mixture)~~

~~(Manufacturer's Name)~~ _____
~~(source code)~~

located in _____,
~~(City)~~ _____ ~~(State)~~

manufactured at _____
~~(Location of Manufacturing Plant)~~

and has Case Review Number _____ meets INDOT Standard Specifications.

~~Attached are copies of the State Seed Commissioner's Letter and test reports for each lot of seed used in the above mentioned seed mixture.~~

Seed Species	Lot No.	Seed Expiration Date
<<All seed species contained in the seed mixture shall be listed in this space.>>		

REVISION TO SPECIAL PROVISIONS

106-C-XXX BUILD AMERICA, BUY AMERICA ACT REQUIREMENTS (proposed new)

I understand that State and/or Federal funds are involved in the work in which this material will be used and that any misrepresentation on my part constitutes fraud.

(Date) (Signature of Company Official)

This _____ pounds of seed mixture, _____ is being provided by
(name of seed mixture)

_____, for INDOT Contract No. _____
(Name of Contractor)

(Date) (Signature of Contractor)

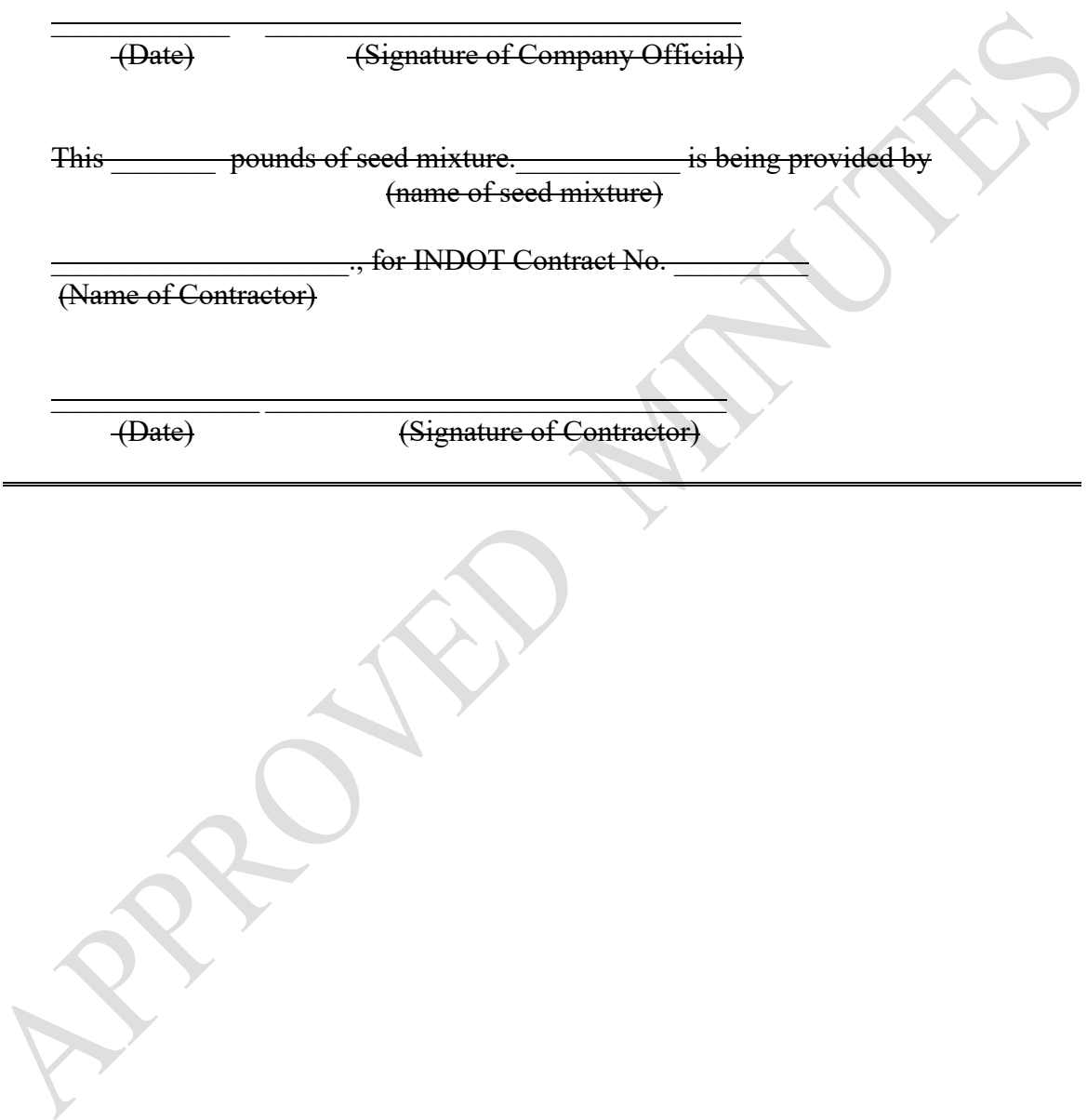

COMMENTS AND ACTION

106-C-XXX BUILD AMERICA, BUY AMERICA ACT REQUIREMENTS

DISCUSSION:

This item was introduced and presented by Mr. Reilman who explained that the Department's Buy America specification requirements need to be updated to comply with the new Federal requirements.

Mr. Reilman proposed to incorporate the proposed edits to bring the Department's specifications into line with the new Federal requirements

With regard to 106.01(c)1(a), Mr. Koch stated that we begin with a MAY statement, and with section (2) we say WILL. The 2nd sentence of section 2 appears to obligate us to make the waiver request and it takes time. Mr. Reilman replied that, per FHWA, we have to make the waiver request.

Mr. Koch asked if the WILL should be MAY? For example: if a minimal amount of foreign steel is required that satisfies section 1 do we need to satisfy both sections and process a waiver? Also, if the waiver is approved, time is likely excusable and non-compensable if on the critical path. With our recent experiences we could potentially receive many requests that may be denied. Ok if we want to proceed as 108.08(c) could still be referenced. I don't believe we changed this language. Thus, it should still be reflective of the Buy America requirements from the CFR, in which it seems the CFR is requiring both sections. Mr. Reilman responded that it needs to remain as-is to remain in unison with the CFR.

With regard to 106.01(c)2, Mr. Koch stated that the language could justify BA not applying to permanent metal deck pans yet needs to be open enough to allow for temporary shoring. Should 'affixed' or something similar be considered? For example: 'All construction materials incorporated permanently into a contract that serve an ongoing need, *or are affixed* to the finished product...'

Mr. Reilman replied that, with discussions with FHWA, we are taking a closer look at things. If something is not beneficial to the contract long term, then our view is that BA is not required. Thus, both metal deck pans and temporary shoring both serve a temporary need and are not needed long term. Similarly for metal sod stakes. Thus, I don't believe any changes are needed.

With regard to 916.02(g), Mr. Koch asked if the word "approved" should be "qualified" or "certified"? Mr. Reilman suggested using the word "acceptable". Mr. Reilman revised his motion.

Further discussion ensued as to whether or not this special provision should be made an RSP or leave it as a USP. Additional revisions may occur due to waiver decisions and will be addressed accordingly. Mr. Duncan clarified the exemptions (concrete, aggregates, HMA, binder materials).

There was no further discussion, at this time, and this item passed as revised. Additional discussions are scheduled to ensue post meeting.

As a result of post meeting:

The RSP **106-C-278 BUY AMERICA REQUIREMENTS** was added. This RSP will be incorporated into 2024 Standard Specifications and will sunset after August 31, 2023.

106-C-277	Build America, Buy America Act Requirements	Required for all Federal Aid contracts.
106-C-278	Buy America Requirements	Required for 100% State-Funded contracts.

COMMENTS AND ACTION

106-C-XXX BUILD AMERICA, BUY AMERICA ACT REQUIREMENTS

[continued]

<p>Motion: Mr. Reilman Second: Mr. Pelz Ayes: 10 Nays: 0 FHWA Approval: Yes</p>	<p>Action: — Passed as Submitted <u>X</u> Passed as Revised — Withdrawn</p>
<p>2022 Standard Specifications Sections referenced and/or affected: 106 pg. 63, 916 pg. 1118 – 1124.</p> <p>Recurring Special Provisions or Plan Details: (Proposed new)</p> <p>Standard Drawing affected: NONE</p> <p>Design Manual Sections affected: NONE</p> <p>GIFE Sections cross-references: NONE</p>	<p><u>X</u> 2024 Standard Specifications (only 106-C-278) — Revise Pay Items List</p> <p><u>X</u> Create RSP (No. <u>106-C-277</u>) and <u>106-C-278</u> Effective: <u>February 1, 2023</u></p> <p>— Revise RSP (No. __) Effective:</p> <p>— Standard Drawing Effective:</p> <p>— Create RPD (No. __) Effective:</p> <p>— GIFE Update — Frequency Manual Update — SiteManager Update</p>